

winkler



HEATED LINES FOR GAS ANALYSIS IN PROCESS MEASUREMENT AND ENVIRONMENTAL MEASUREMENT



Heated analysis lines for stationary and mobile applications

Heated filters

Junction heating and insulation

Heated mixing vessels and housing

THE WINKLER SERVICE PHILOSOPHY

For Winkler service is an aspiration and a driving force. For all our products we offer:

Competent advice - We speak your language

Our application specialists are there for you. We analyse your problem with you and together we find a solution. Communication with our customers is important for us.

Innovative product ideas - something is emerging

Together with you, we develop ideas that we turn into new products. By combining our expertise with our customers' concepts, we join forces to gain a head start in the market. We offer fast and smooth implementation from the product idea through to the end product. On request you will receive your own OEM item number and an identifier for the heated line according to your specifications.

Customer-oriented after-sales service – for the benefit of our customers

After the delivery is before the delivery ...

For Winkler prompt delivery is not an end in itself. We look forward to seeing the satisfaction on your faces.

Fast delivery - Because your time is precious

We stock all the materials in this catalogue (unless noted otherwise) this is how we can supply your heated line within 2 weeks of order receipt - worldwide incl. all customs formalities.

There is the possibility of integrating the components or documents you provide in our shipment. Neutral packaging on request.

Our service does not finish with the delivery of our products. On the move for you means being open for wishes and suggestions.

Our corporate philosophy puts the focus on your satisfaction.

For your orders please contact our Customer Centre at sales@winkler.org, Tel. +49 6221 3646 0.

THE „SEVEN“ QUALITY HALLMARKS OF WINKLER HEATED LINES

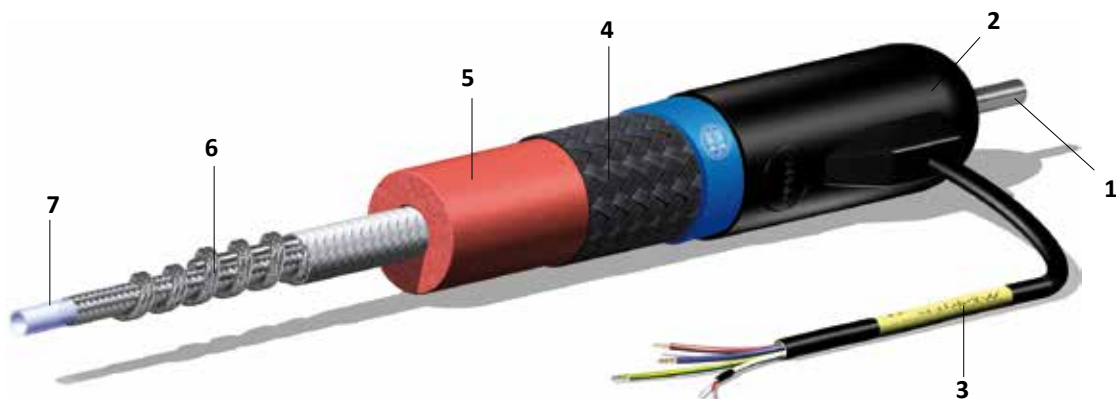

1. Fittings

- Stainless steel 1.4571 (V4A) in analytic quality
- Special materials optional, such as Hastelloy
- Customer requests can be taken into consideration

2. Termination of lines

- With silicone caps or with screw connections
- Robust, durable, thermally stable
- Electrostatically conductive for ATEX applications
- Custom printing possible on request

3. Electrical connection

- Ready for connection with ferrules or plugs, customized solutions possible
- Various designs for the cable outlet enhance adaptability
- High quality silicone protective hose, corrugated hose optional

4. Outer jacket

- Various materials from polyamide to stainless steel with high chemical resistance and UV protection
- Electrostatically conductive PA outer jacket for ATEX applications
- IP54 with corrugated hose or IP65 with co-extruded silicone
- Colour coding of the nominal diameter or the sensor position(s)

5. Insulation

- Various insulation materials up to 250 °C (higher temperatures possible on request)
- Various insulation thicknesses from 30 mm (analysis cabinet installation) to 60 mm (e.g. for use in extreme climatic zones)
- Effective insulation, low energy consumption, low waste heat

6. Heating und sensors

- High quality, VDE-certified and moisture-protected heating cables and tapes
- Self-limiting heating tapes and parallel heating tapes for cutting to length on-site with self-termination
- High quality sensor system, e.g. Pt100, with a two, three or four wire technology or J and K type thermocouples
- Application-specific power adjustment optional

7. Inner line

- Inner line made of various materials (fluoropolymers, stainless steel), also electrostatically conductive for ATEX applications
- Analysis quality
- Guaranteed constant wall thickness, min. 1 mm
- Copper or stainless steel braiding for mechanical stabilisation of the inner line and for improved heat distribution

Content

The Winkler Service Philosophy..... 2

The „Seven“ Quality Hallmarks of Winkler Heated Lines..... 2

1. Heated lines self-configured with the Winkler modular system 4

 1.1 The modular system - the article number

 1.2 The modular system - the series

2. Heated lines with thermal fleece insulation and protective hose 6

3. Heated lines with Silicone foam insulation and protective braiding/silicone cover 8

4. Versions of heating elements.....10

5. Technical data of heated hoses with different heating elements11

6. Versions of inner lines 12

7. Fittings and accessories14

8. Technical versions and options 15

9. Accessories and spare parts.....16

10. Insulations 18

11. Junction heating for ferrule fitting20

12. Mounting brackets 22

13. Connection system Quick-Lock.....24

14. Heated filter series WAZF.....26

15. Soot particle filter 28

16. Heating mixing vessel 30

17. Heated 19" housings 32

1. HEATED LINES SELF-CONFIGURED WITH THE WINKLER MODULAR SYSTEM

A heated line in the Winkler modular system consists of:

- 1. Basic items:** containing all length-independent modules, such as fittings, I/O termination, sensors and connecting cable. The price is fixed.
- 2. Metre items:** including all length-dependent modules, such as outer jacket, insulation, heating element and inner line. The price is calculated by the metre.
- 3. Options:** including e.g. strain relief, supply lines and special fittings. The price per module is calculated individually. Ordering optional.

Each heated line has two sides: Towards the sampling probe the **a-side** (always shown on the left) and the e-side with the electrical connection (always shown on the right).

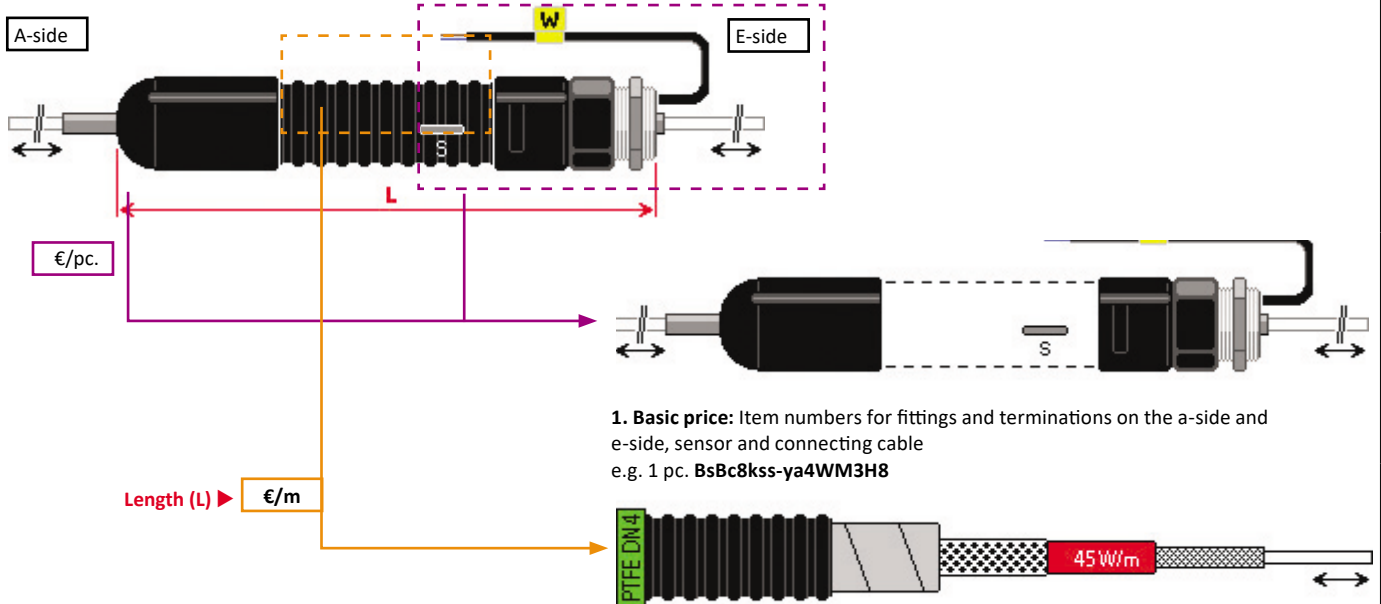

1. Basic price: Item numbers for fittings and terminations on the a-side and e-side, sensor and connecting cable
e.g. 1 pc. **BsBc8kss-ya4WM3H8**

2. Metre price: Item number for heated lines (please order the quantity according to the length of the heated line)
e.g. L m **BsMW2H24-1t04Xt18**

3. Options (from the generally applicable list and/or available for the respective series)
e.g. 1 pc. BUO... + 1pc. BUO...

1.1 The modular system - the article numbers

Every item in the modular system has its own code. The codes of the required basic and metre items each form a 17-digit article number. Both article numbers are required for ordering a heated line. Options have their own article numbers.

► Structure and codes for Basic items (basic price €/m)

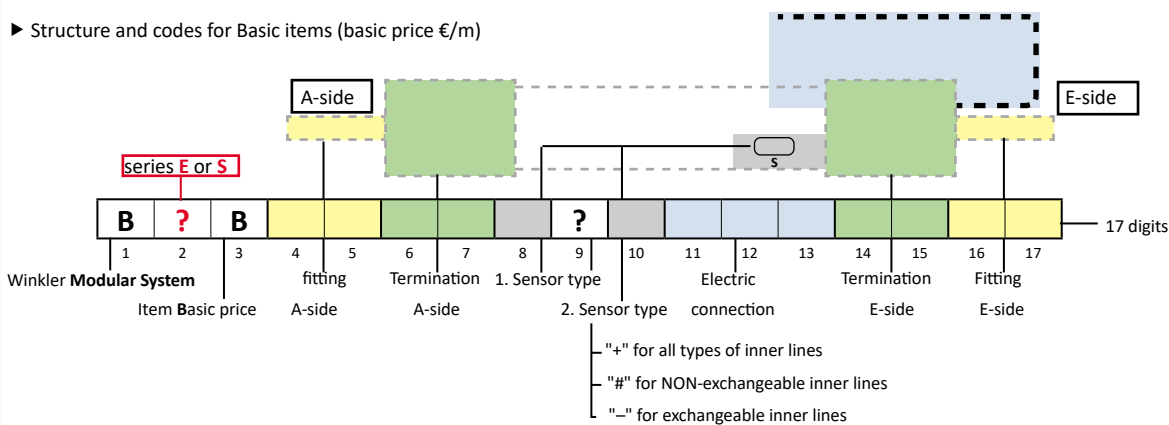

► Structure and codes for Metre items (metre price €/m)

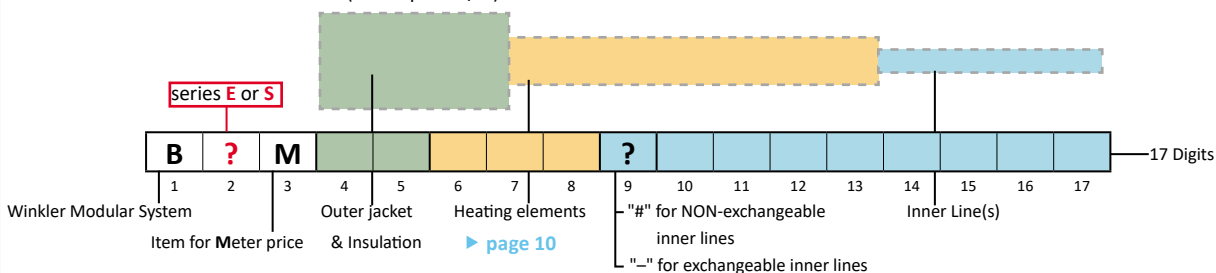

1.2 The modular system - the series

Three different series of heated lines are distinguished in the modular system:

- Economy Series
- Standard Series

The different series take different technical features and application areas into consideration.

The decision tree makes it easier for you to choose:

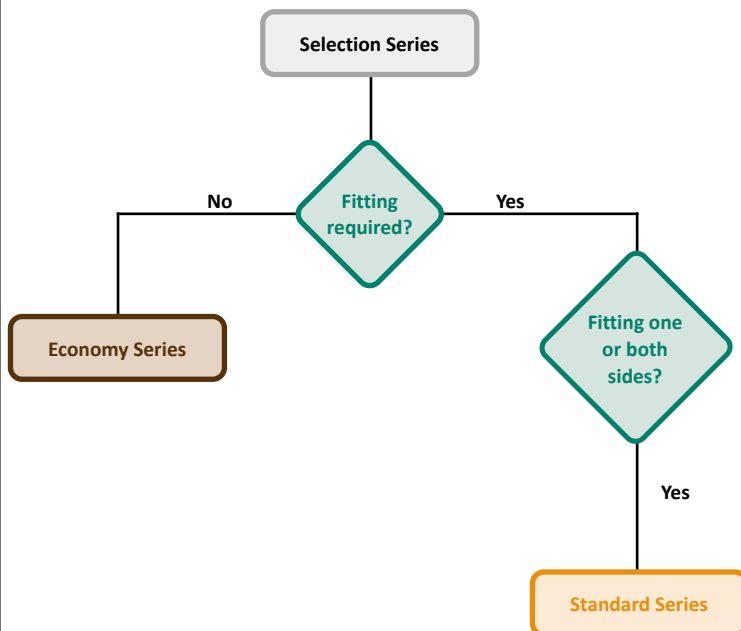

Economy Series

- no fittings
- for stationary use
- Inner line optionally exchangeable or non-exchangeable
- Inner line without stainless steel braiding
- Inner line protrudes unheated on the a- and e-side

Length definition

- from silicone cap to silicone cap

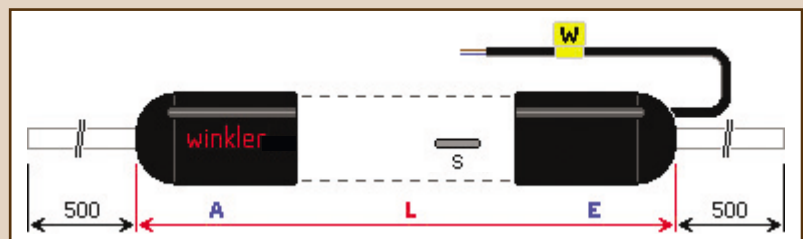

Standard Series

- fitting two-sided, on A- and E-side
- fitting on one side and cable projection on the other side
- for mobile and stationary use with mechanical load or pressure stress
- inner line optionally exchangeable or non-exchangeable
- inner line with heavy stainless-steel braiding
- if exchangeable, inner line protrudes unheated

Length definition

- from fitting to fitting

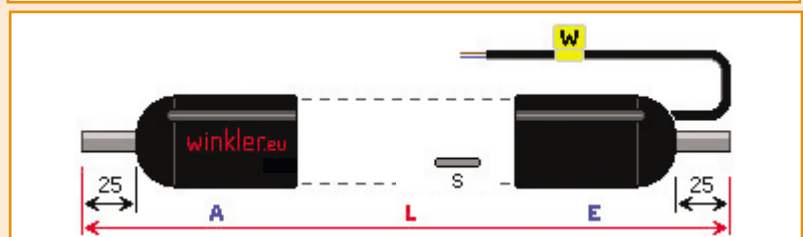
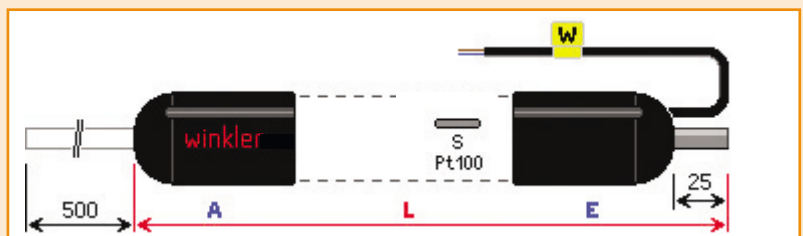
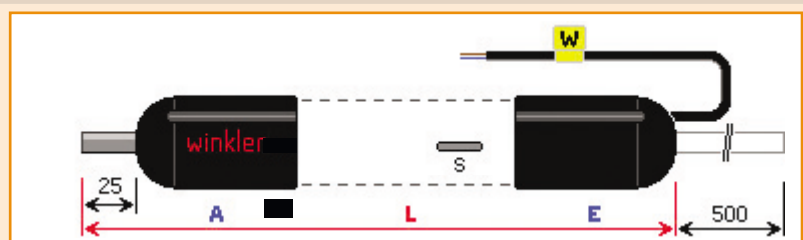

Application

Flexible heated lines for transporting measurement gas samples up to 200°C. Especially suited for fixed installation - especially for outdoors – with normal and high mechanical stress (protective hose made of PA / protective hose made of metal).

Structure with heating cable

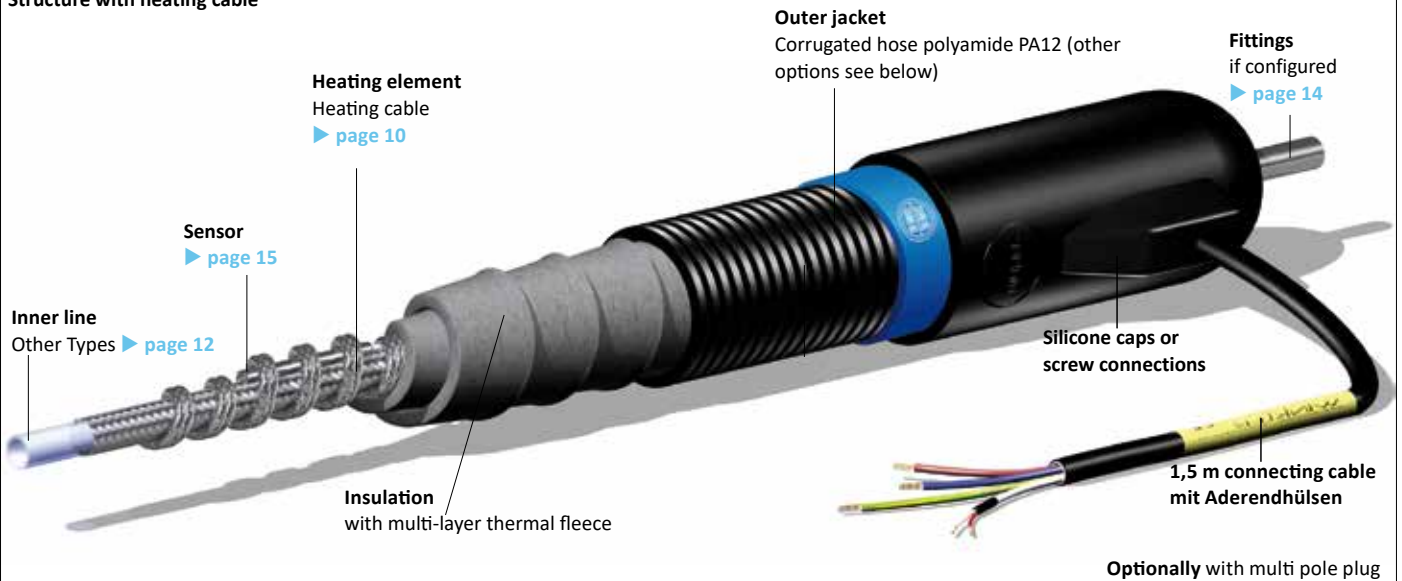

Structure with heating tape



Optionally with multi pole plug



Features and benefits

- inner line according to configuration [▶ page 12](#)
- heating element according to configuration [▶ page 10](#)
- flexible insulation structure with multi-layer thermal fleece
- regular design for insulation structure approx. 43 mm and approx. 53 mm (for bundle lines)
- outer jacket with robust protective hose in various versions (see below) and silicone caps or screw connections
- permanently installed temperature sensor (regulated heating elements) [▶ page 15](#)
- ready for connection with ferrules or optionally with multi pole plug



Operation with controller
[▶ Catalogue Temperature controllers](#)

Versions of outer jackets: protective hoses

Option: Silicone skin

<p>Code W2 Corrugated hose polyamide (PA 12) black Used for standard applications Outer diameter of insulation ca. 43 mm</p>	<p>Code T2 Galvanised steel strip wound hose. Treadable. Application for higher stresses. Outer diameter of insulation ca. 43 mm</p>	<p>Art.-no. BU0W2ESB Silicone skin, black, 1 mm thick. Application with W2, protects against aging (esp. due to UV irradiation)</p>
<p>Code W3 Corrugated hose polyamide (PA 12) black Application for bundle lines down to -40 °C Outer diameter of insulation ca. 53 mm</p>	<p>Code U2 Stainless steel strip wound hose. Treadable. Ideal for durable perfect appearance. Outer diameter of insulation ca. 43 mm</p>	<p>Art.-no. BU0W2EEB EPDM skin, black, 1,5 mm thick. Application with W2, protects against aging (esp. due to UV irradiation) and against aggressive, aqueous chemicals</p>

Versions of terminations

Depending on the application the heated lines can be terminated with silicone caps or metric screw connections on both the electrical connection side (E-side) or the sample side (A-side). Please indicate the kind of termination you need when ordering.

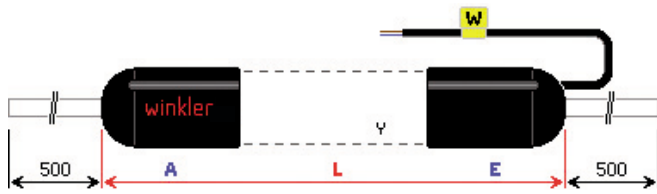

Silicone caps on both sides

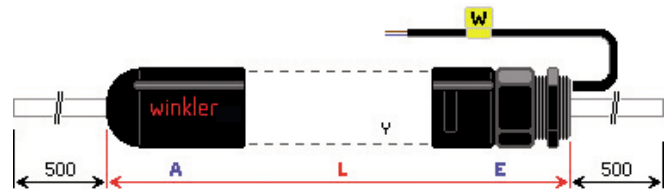

A-side silicone cap; E-side screw connection

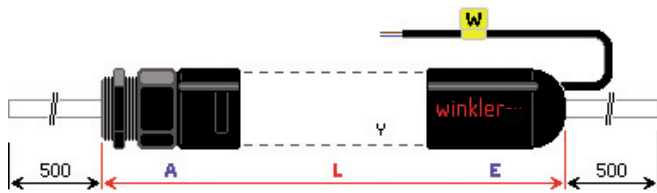

A-side screw connection; E-side silicone cap

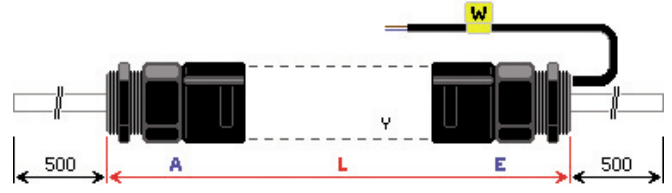

A-side screw connection; E-side screw connection

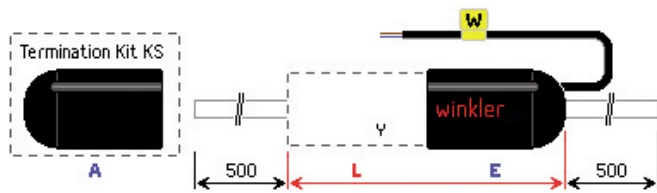

A-side open; E-side silicone cap* (termination set enclosed)

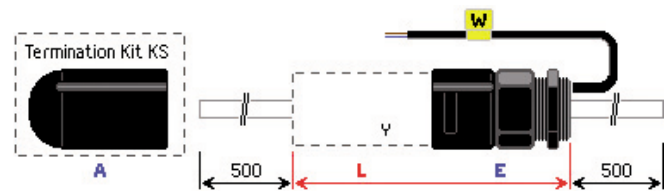

A-side open; E-side screw connection* (termination set enclosed)

* Only for heated lines with heating tapes for cutting to length.

Codes for terminating the ends of the line

KS: Silicone cap smooth
 KK: Silicone cap with cable outlet

P3: Plastic screw connection PG36 thread
 M3: Metal screw connection PG36 thread
 M4: Metal screw connection M40 thread

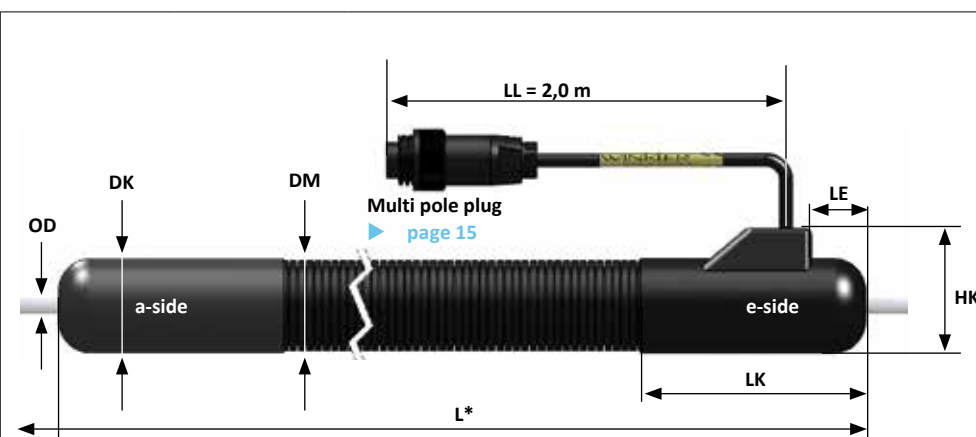

L*: Length of the heated line
 Definition varies depending on the series and fitting
 ▶ [page 5](#)
 Here an example of the Economy series

OD: Outer diameter inner line
DK: Outside diameter of cap
DM: Outside diameter of outer jacket
LK: Length of cap
LE: Recess of cable outlet
LL: Length of connecting cable
HK: Height of cap with cable outlet
A-Seite: Sample side
E-Seite: Electric connection side

dimensions and bend radii (Tolerances of length ±2%, tolerances of diameter ±5%)

DN (nom. diam)	2	4	6	8	10	13	16
OD	4 mm	6 mm	8 mm	10 mm	12 mm	15 mm	18 mm
DK				48 mm			
DM				42,5 mm			
LK				120 mm			
LE				25 mm			
HK				62 mm			
Min. bend radius	200 mm				300 mm		

Application

Flexible heated lines for transporting measurement gas samples up to 250°C. Especially suited for mobile use, the version with silicone outer jacket is for installation in control cabinets and outdoor application. Heated lines with protective braiding as an outer jacket are suitable for fixed installation indoors under normal mechanical stress.

Structure

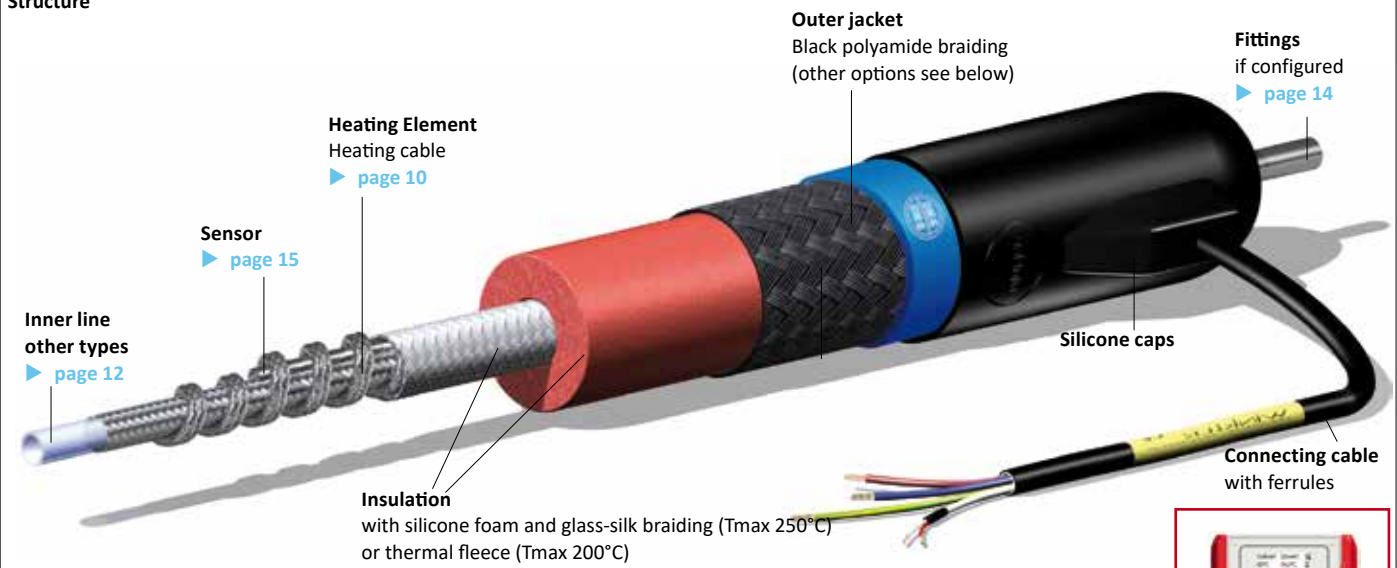

Features and benefits

- inner line according to configuration
- heating element according to configuration
- soft and extremely flexible insulation structure with glass-silk braiding (Tmax 250°C) and silicone foam
- regular design insulation structure approx. 43 mm (up to DN 16) and approx. 63 mm (above DN 20), insulation versions see below
- outer jacket with protective braiding or silicone covers and silicone caps
- permanently installed temperature sensor (regulated heating elements)
- ready for connection with ferrules or optionally with multi pole plug

optionally with multi pole plug



Operation with controller
▶ Catalogue Temperature controllers

Versions of outer jackets: protective braidings and silicone cover

<p>Code G2</p> <p>Black polyamide braiding Used for standard applications Outer diameter of insulation ca. 43 mm</p>	<p>Code Z2</p> <p>Galvanised steel braiding. High durability. Outer diameter of insulation ca. 43 mm</p>	<p>Code S1</p> <p>Black silicone cover, washable. Outer diameter ca. 33 mm. Ideal for control cabinets + mobile use. Available length up to 30 m.</p>
<p>Code G3</p> <p>Black polyamide braiding Outer diameter of insulation ca. 53 mm Use down to -40 °C</p>	<p>Code V2</p> <p>Stainless steel braiding. Maximum durability. Ideal for durable perfect appearance. Outer diameter of insulation ca. 43 mm</p>	<p>Code S2</p> <p>Black silicone cover, washable. Outer diameter ca. 43 mm. Combines flexibility and durability. Available lengths up to 20 m.</p>
<p>Code S3</p> <p>Black silicone cover, washable. Outer diameter ca. 53 mm. Combines flexibility and durability. Available lengths up to 20 m. Use down to -40 °C</p>		

Technical Data

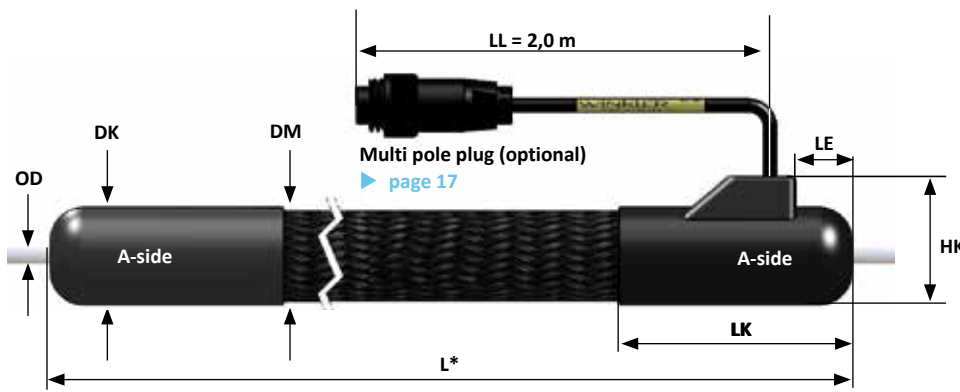

- L*:** Length of the heated line
Definition varies depending on the series and fitting
▶ [page 4](#)
Here an example of the Economy series
- OD:** Outer diameter inner line
- DK:** Outside diameter of cap
- DM:** Outside diameter of outer jacket
- LK:** Length of cap
- LE:** Recess of cable outlet
- LL:** Length of connecting cable
- HK:** Height of cap with cable outlet
- A-side:** Sample side
- E-side:** Electric connection side

Dimensions and bend radiuses (Tolerances of length $\pm 2\%$, tolerances of diameter $\pm 5\%$)

DN (nom. diam.)	2	4	6	8	10	13	16
OD	4 mm	6 mm	8 mm	10 mm	12 mm	15 mm	18 mm
DK	48 mm			52 mm			
DM	43 mm				46 mm		
LK	120 mm			140 mm			
LE	25 mm						
HK	64 mm						
Min. bend radius	160 mm				250 mm		

4. VERSIONS OF HEATING ELEMENTS

1. Self limiting heating tapes

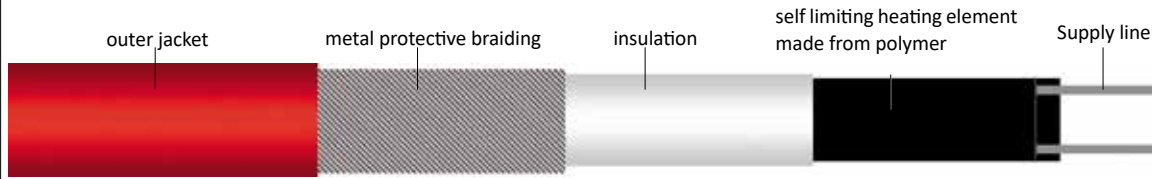

operation without controller

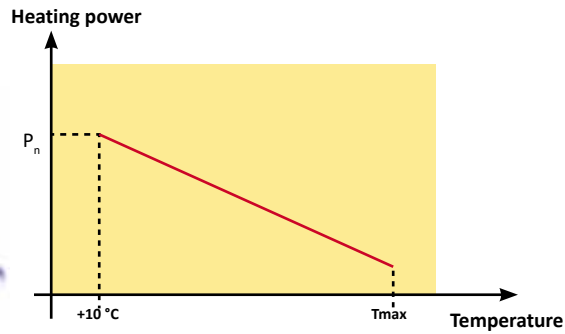

2. Parallel heating tapes

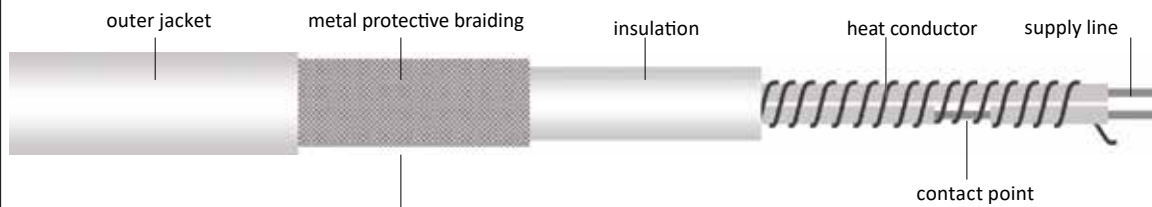

Operation with controller
 ▶ Catalogue Temperature controllers

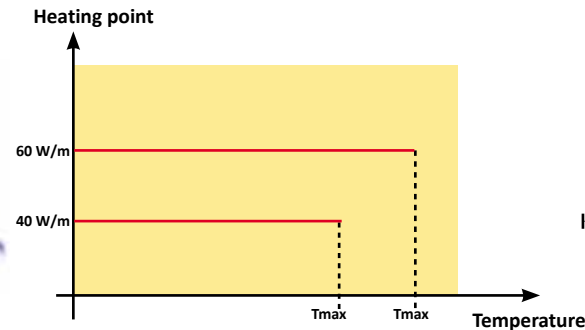
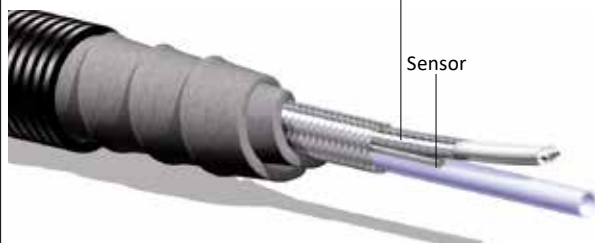

3. Heating tape

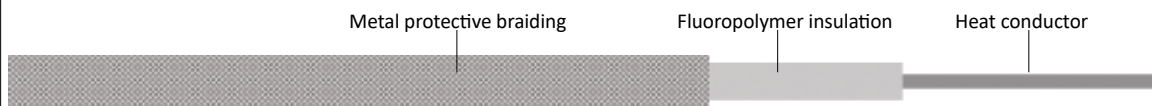

Operation with controller
 ▶ Catalogue Temperature controllers

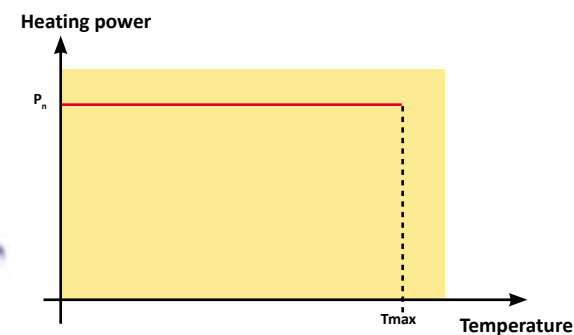
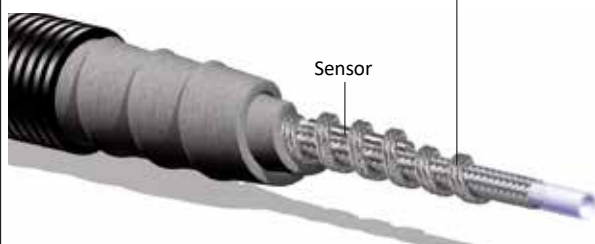

5. Technical data of heated hoses with different heating elements

Heated lines with self-limiting heating tapes and parallel heating tapes

Technical data for 230 vac* (Tolerance of power specifications: ±10%, Tu: ambient temperature)

Code	L20	L22	L24	L26	H22	H24	H26	P24	P26
Power at $T_u = +10\text{ °C}$	10 W/m	15 W/m	26 W/m	33 W/m	25 W/m	45 W/m	60 W/m	40 W/m	60 W/m
Hold temperature at $T_u = +20\text{ °C}$	30 - 40 °C	35 - 45 °C	40 - 50 °C	50 - 60 °C	70 - 80 °C	70 - 80 °C	110 - 120 °C	-	-
Hold temperature at $T_u = -20\text{ °C}$	5 - 15 °C	10 - 25 °C	20 - 35 °C	30 - 45 °C	50 - 60 °C	70 - 80 °C	110 - 120 °C	-	-
Max. perm. operating temp. with Power ON	65 °C				120 °C			120 °C	200 °C
Max. perm. operating temp. with Power OFF	85 °C				190 °C			200 °C	260 °C
Permissible range of ambient temperature	-40 °C bis +40 °C								
Max. manufactured length	80 m								
Max. heating circuit length at $T_u = -30\text{ °C}$ (16 A Sich.)	120 m	77 m	45 m	43 m	88 m	49 m	38 m	90 m	60 m
Max. heating circuit length at $T_u = -30\text{ °C}$ (20 A Sich.)	150 m	106 m	64 m	52 m	120 m	66 m	52 m	100 m	75 m
Max. heating circuit length at $T_u = -30\text{ °C}$ (32 A Sich.)	195 m	160 m	100 m	82 m	140 m (only -25 °C)	82 m (only -25 °C)	64 m (only -25 °C)	100 m	75 m

* 115 V available on request

Heating lines with heating cable

Maximum operating temperatures, powers, line lengths with a heating circuit for 230 VAC and 115 VAC* (ambient temperature -20 °C to +40 °C, tolerance of power specifications ±10%, tolerance of length specifications ±2%, tolerance of diameter specifications ±5%)

T_{max}	Volt	DN ->	2	4	6	8	10	13
100 °C	230 V	non-exchangeable (code)	-	80 W/m (C14)			100 W/m (C2A)	100 W/m (C2B)
		exchangeable (code)	80 W/m (C14)		100 W/m (C2A)	100 W/m (C2B)	-	-
		max. length	52 m				41 m	
	115 V	fest (Code)	-	80 W/m (A14)			100 W/m (A2A)	100 W/m (A2B)
		exchangeable (code)	80 W/m (A14)		100 W/m (A2A)	100 W/m (A2B)	-	-
		max. length	25 m				20 m	
200 °C	230 V	non-exchangeable (code)	-	100 W/m (C24)			125 W/m (C3A)	125 W/m (C3B)
		exchangeable (code)	100 W/m (C24)		125 W/m (C3A)	125 W/m (C3B)	-	-
		max. length	52 m				41 m	
	115 V	non-exchangeable (code)	-	100 W/m (A24)			125 W/m (A3A)	125 W/m (A3B)
		exchangeable (code)	100 W/m (A24)		125 W/m (A3A)	125 W/m (A3B)	-	-
		max. length	25 m				20 m	
250 °C	230 V	non-exchangeable (code)	-	125 W/m (C34)			150 W/m (C4A)	150 W/m (C4B)
		exchangeable (code)	125 W/m (C34)		150 W/m (C4A)	150 W/m (C4B)	-	-
		max. length	41 m				34 m	
	115 V	non-exchangeable (code)	-	125 W/m (A34)			150 W/m (A4A)	150 W/m (A4B)
		exchangeable (code)	125 W/m (A34)		150 W/m (A4A)	150 W/m (A4B)	-	-
		max. length	20 m				17 m	

* other voltage available on request

6. VERSIONS OF INNER LINES

Nominal diameters DN



Important!

The nominal diameter **DN** of an heated line always refers to the inner diameter **ID** in mm of the inner line.*

Attention!



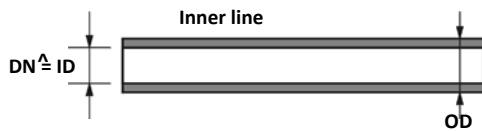





The nominal diameter is not to be confused with the dimensions of the fitting.



Nominal diameter DN	Nominal diameter Code	Inner diameter ID inner line	Outer diameter OD inner line
4	4	4	6
6	6	6	8
8	8	8	10
10	A	10	12
13	B	13	15
16	C	16	18

*Exception for inch dimensions

Materials for inner lines**

	<input type="checkbox"/> Economy-Series <input type="checkbox"/> Standard-Series (exchangeable)		<input type="checkbox"/> Standard-Series (non-exchangeable) Higher pressure resistance and mechanical stress – thanks to strong stainless-steel braiding.	
	metric	inch		
 PTFE hose ▶ Code "T"	DN4 DN6 DN8 DN10 DN13	1/4" OD 3/8" OD		DN4 DN6 DN8 DN10 DN13
 PTFE hose, electrostatically conductive ▶ Code "A"	DN4 DN6 DN8 DN10	X		DN4 DN6 DN8 DN10
 PFA hose ▶ Code "P"	DN4 DN6 DN8	1/4" OD 3/8" OD		DN4 DN6
 PFA hose, electrostatically conductive ▶ Code "S"	DN4 DN6++	X	X	X
 FEP hose ▶ Code "F"	DN4 DN6 DN8	X	X	X
 Stainless steel tube ▶ Code "K"	DN4 DN6 DN8 DN10	1/16" OD 3/8" OD	X	X

**Other dimensions and materials, such as MFA, ETFE, polished stainless steel tubes and special alloys, on request.





Versions without fittings

Economy-Series ► no fittings (exchangeable inner line possible)

 <p>X8 Fluoropolymer inner line (both sides protruding 500 mm)</p>	 <p>X8 Stainless steel tube (both sides protruding 500 mm)</p>
 <p>X8 Exchangeable fluoropolymer inner line in PTFE carrier line (both sides protruding 500 mm)</p>	 <p>X8 Bundle line (2 to 8 inner lines, both sides protruding 500 mm)</p>

Versions for fittings

Standard Series ► fitting on one side (inner line non-exchangeable)





A-side	E-side
 <p>X8 Fluoropolymer inner line with light stainless-steel braiding (on A-side protruding 500 mm)</p>	 <p>R2 Fluoropolymer inner line with light stainless-steel braiding + stainless steel tube stub (RSL fitting)</p>
OR	
 <p>R2 Fluoropolymer inner line with light stainless-steel braiding + stainless steel tube stub (RSL fitting)</p>	 <p>X8 Fluoropolymer inner line with light stainless-steel braiding (on A-side protruding 500 mm)</p>

Standard Series ► fittings on both sides (exchangeable inner line possible)

Non-exchangeable inner line

 <p>R2 Fluoropolymer inner line with strong stainless-steel braiding + stainless-steel tube stub (RSL fitting)</p>
--

Exchangeable inner line

 <p>H8 PTFE-carrier line with strong stainless-steel braiding + exchangeable fluoropolymer inner line (both sides protruding 500 mm)</p>	 <p>RW PTFE-carrier line with strong stainless-steel braiding + exchangeable fluoropolymer inner line and exchangeable RSL fittings ► page 14</p>
 <p>C8 PTFE-carrier line with strong stainless-steel braiding + exchangeable fluoropolymer inner line (both sides protruding 500 mm) + stainless steel tube stub (RSL fittings)</p>	 <p>F8 PTFE-carrier line with strong stainless-steel braiding + exchangeable fluoropolymer inner line (both sides protruding 500 mm) + stainless steel ferrule fittings</p>

7. FITTINGS AND ACCESSORIES





Dimensions for fittings version R2

	DN	ID (mm)	RSL	
			OD* (mm)	LA** (mm)
	4	4	6	25
	6	6	8	25
	8	8	10	26
Material: stainless steel 1.4571	10	10	12	26

* Outer diameter of fitting

** Length of fitting (up to a max. length of 500 mm every other length is possible as an option)

Accessories for fittings version RW: tube stubs

	Base DN 4		Base DN 6		Base DN 8	
	ID/OD (mm) tube stub		ID/OD (mm) tube stub		ID/OD (mm) tube stub	
L = 25 mm 	4/6	BUZW24Z6	4/6	BUZW26Z6	–	–
	6/8	BUZW24Z8	6/8	BUZW26Z8	6/8	BUZW28Z8
	–	–	8/10	BUZW26ZA	8/10	BUZW28ZA
L = 50 mm 	ID/OD (mm) tube stub		ID/OD (mm) tube stub		ID/OD (mm) tube stub	
	4/6	BUZW54Z6	4/6	BUZW56Z6	–	–
	6/8	BUZW54Z8	6/8	BUZW56Z8	6/8	BUZW58Z8
	–	–	8/10	BUZW56ZA	8/10	BUZW58ZA
L = 100 mm 	ID/OD (mm) tube stub		ID/OD (mm) tube stub		ID/OD (mm) tube stub	
	4/6	BUZW74Z6	4/6	BUZW76Z6	–	–
	6/8	BUZW74Z8	6/8	BUZW76Z8	6/8	BUZW78Z8
	–	–	8/10	BUZW76ZA	8/10	BUZW78ZA
L = 150 mm 	ID/OD (mm) tube stub		ID/OD (mm) tube stub		ID/OD (mm) tube stub	
	4/6	BUZW84Z6	4/6	BUZW86Z6	–	–
	6/8	BUZW84Z8	6/8	BUZW86Z8	6/8	BUZW88Z8
	–	–	8/10	BUZW86ZA	8/10	BUZW88ZA
L = 200 mm 	ID/OD (mm) tube stub		ID/OD (mm) tube stub		ID/OD (mm) tube stub	
	4/6	BUZW94Z6	4/6	BUZW96Z6	–	–
	6/8	BUZW94Z8	6/8	BUZW96Z8	6/8	BUZW98Z8
	–	–	8/10	BUZW96ZA	8/10	BUZW98ZA

Accessories for fitting version RW: exchangeable Quick Lock fitting [▶ page 25](#)

8. TECHNICAL VERSIONS AND OPTIONS

Operating voltages

230 V AC-50 Hz, 12 V AC, 24 V AC, 48 V AC, 100 V AC, 115 V AC, 120 V AC, 200 V AC, 240 V AC, 400 V AC, 480 V AC, 12 V DC, 24 V DC, 48 V DC
Other voltages available on request.

One heating circuit = one heating zone

Multiple heating circuits ► multiple heating zones
Three phase version possible.

Temperature sensors

Versions of sensor types

- Resistance thermometer Pt 100 (2 wire) (potential free) **Code XP**
- Thermocouple type K (NiCr-Ni) (potential free) **Code XK**
- Thermocouple type J (Fe-CuNi) (potential free) **Code XJ**
- Resistance thermometer Pt 100 (3 wire) **Code XT**
- Resistance thermometer Pt 100 (4 wire) **Code XQ**
- Bi-metal temperature controller **Code XB**
- Temperature fuse **Code XS**

Sensor position:

The sensor position is always measured from the electrical connection side (E-side). Please indicate your desired sensor position LS in your order.

Depending on the length L of the heated line, LS is preset by us at

$L \leq 5 \text{ m}$, $l_s = 300 \text{ mm}$

$L > 5 \text{ m}$, $l_s = 2 \text{ m}$

The correct position of the sensor is particularly important in cases of (partial) installation in switch cabinets, through walls or outdoors. Please ask our specialists for advice.

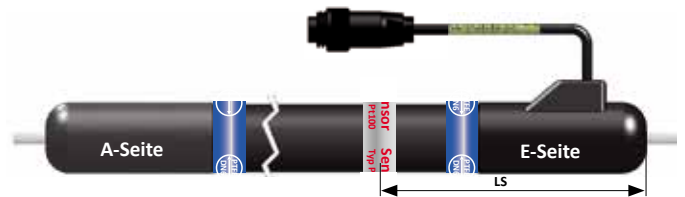

Versions of multiple sensors and sensor combinations:

Multiple sensors

- 2 x Pt 100 (2 wire) **Code ZP**
- 3 x Pt 100 (2 wire) **Code DP**
- 2 x thermocouple type K (potential free) **Code ZK**
- ...ect.

Sensor combination e.g. Pt100 + thermocouple type K **Code PK**
...ect.



Important!

Exposure to wind, as in the case of outdoor installations, can cool down the heated line quite considerably.

Under these conditions, the heated line should be laid with appropriate protection, provided with stronger insulation (see options) and/or more power (W/m), while the temperature sensors have to be strategically placed. If the heated line runs through areas with different ambient temperatures, the internal line temperature will vary accordingly. This can be prevented by incorporating different heating zones with separate control.

Option thermal fuse:

Please specify your desired position of the thermal fuse when placing an order. The correct position of the thermal fuse is especially important in case the heated line is (partly) installed in switching cabinets, outdoors or put through walls. Please consult our specialists for this.



Connecting cable and plugs

Versions

- electric connecting cable and sensor cable lead through together
- electric connecting cable and sensor cable separately lead through
- connection versions type 1 to type 5 see below
- length of connecting cable: possible from 0,1 m onwards
- plugs: 7-pin multi pole plug (< 10 A), 5-pin multi pole plug (< 20 A)
- other plugs: A type and design apart from the standard design can be determined as per your requirements. If you do not know the exact type, send us a sample and the pin assignment.
- without plug (cable ends with ferrules)

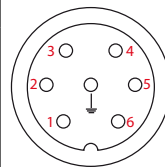

Pin assignment (7-pin multi pole plug)

- 1: Power (L)
- 2: Power (N)
- 3: free
- 4: free
- 5: Sensor (+)
- 6: Sensor (-)
- PE: Earth

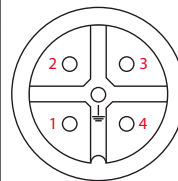

Pin assignment (5-pin multi pole plug)

- 1: Power (L)
- 2: Power (N)
- 3: Sensor (+)
- 4: Sensor (-)
- PE: Earth

Type 1



Type 2



Type 3



Type 4

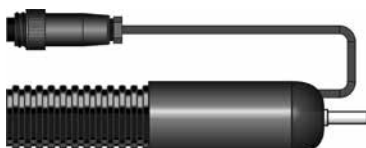

Type 5

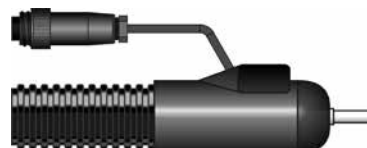

9. ACCESSORIES AND SPARE PARTS

Plugs, couplings and flange sockets

Art.-no. **WZZS0904-2507P10A**
Multi pole plug 6+PE (7 pin) with cap
250 V, 10 A, IP 65, screw connections,
-40 °C / +100 °C



Art.-no. **WZZS0908-2507P10A**
Coupling 6+PE (7 pin) with cap
250 V, 10 A, IP 65, screw connections,
-40 °C / +100 °C



Art.-no. **WZZS0906-2507P10A**
Flange socket 6+PE (7 pin) with cap and screw
250 V, 10 A, IP 65, screw connections,
-40 °C / +100 °C



Art.-no. **WZZS0939-4005P20A**
Multi pole plug 4+PE (5 pin) with cap
400 V, 20 A, IP 65, screw connections,
-40 °C / +100 °C



Art.-no. **WZZS0971-4005P20A**
Coupling 4+PE (5 pin) with cap
400 V, 20 A, IP 65, screw connections,
-40 °C / +100 °C



Art.-no. **WZZS0940-4005P20A**
Flange socket 4+PE (5 pin) with cap and screw
400 V, 20 A, IP 65, screw connections,
-40 °C / +100 °C



Art.-no. **WZZS0942-4004P16A**
Multi pole plug 3+PE (4 pin) with cap
400 V, 16 A, IP 65, screw connections,
-40 °C / +100 °C



Art.-no. **WZZS0943-4004P16A**
Coupling 3+PE (4 pin) with cap
400 V, 16 A, IP 65, screw connections,
-40 °C / +100 °C



Art.-no. **WZZS0993-4004P16A**
Flange socket 3+PE (4 pin) with cap and screws
400 V, 16 A, IP 65, screw connections,
-40 °C / +100 °C



Silicone caps

Applications Covering of line ends, repair of outer covers, strengthening of passages, manufacturing of insulations.
Technical Data Black, smooth, elastic and extremely tear proof. Wall thickness approx. 3 mm. High chemical resistance.
Handling Very low humidity absorption, very good elasticity. Long time temperature stability -60 °C / + 240 °C. Tolerances of dimensions ±10%
 Cut with a sharp knife. Expand slightly to cover and glue with silicone Art.-no. WZZ00629-000ST090.

<p>Art.-no. WZK00715-028SB034</p> <ul style="list-style-type: none"> · black silicone cap · without cable outlet · ID 28 mm · OD 34 mm · length 100 mm 	<p>Art.-no. WZK00709-038SB044</p> <ul style="list-style-type: none"> · black silicone cap · without cable outlet · ID 39 mm · OD 45 mm · length 120 mm 	<p>Art.-no. WZK00704-058SB064</p> <ul style="list-style-type: none"> · black silicone cap · without cable outlet · ID 58 mm · OD 64 mm · length 140 mm 
<p>Art.-no. WZK00716-028SB034</p> <ul style="list-style-type: none"> · black silicone cap · with cable outlet · ID 28 mm · OD 34 mm · length 100 mm 	<p>Art.-no. WZK00708-038SB044</p> <ul style="list-style-type: none"> · black silicone cap · with cable outlet · ID 39 mm · OD 45 mm · length 120 mm 	<p>Art.-no. WZK00703-058SB064</p> <ul style="list-style-type: none"> · black silicone cap · with cable outlet · ID 58 mm · OD 64 mm · length 140 mm 

Silicone foam hoses

<p>Art.-no. WZXS3600 Fixation clamps made of plastic</p> 	<p>Art.-no. WZZ00629-000ST090 Transparent silicone glue: 90 ml tube incl. nozzle and winding hook</p> 
--	--

10. INSULATIONS

Art.-no. WAZX1130

Insulation jacket

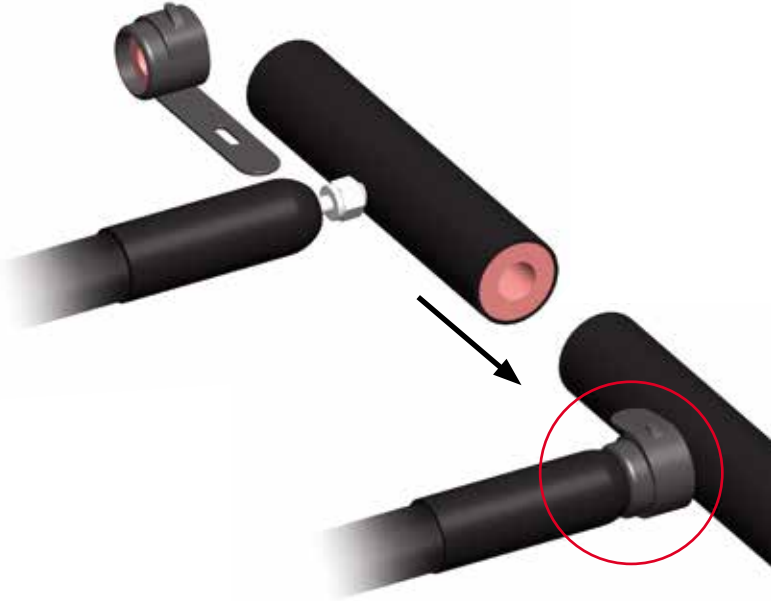

Material / features

- silicone (silicone elastomer with additives)
- outstanding mechanical and chemical resistance
- very good thermal and electrical insulation
- long term temperature stability -60°C to 200°C

Applications

- junction insulation for ferrule fittings / cutting ring screw connections to pipe OD6 mm, OD8 mm and 1/4" (OD6,35 mm)
- suitable for straight connectors
- avoids condensation in the connection area
- protection against contact and mechanical strain

Dimensions / sketch

- outer diameter: 35 mm
- inner diameter: 16 mm
- length: 30 mm

Art.-no. WAZX1131

Insulation jacket

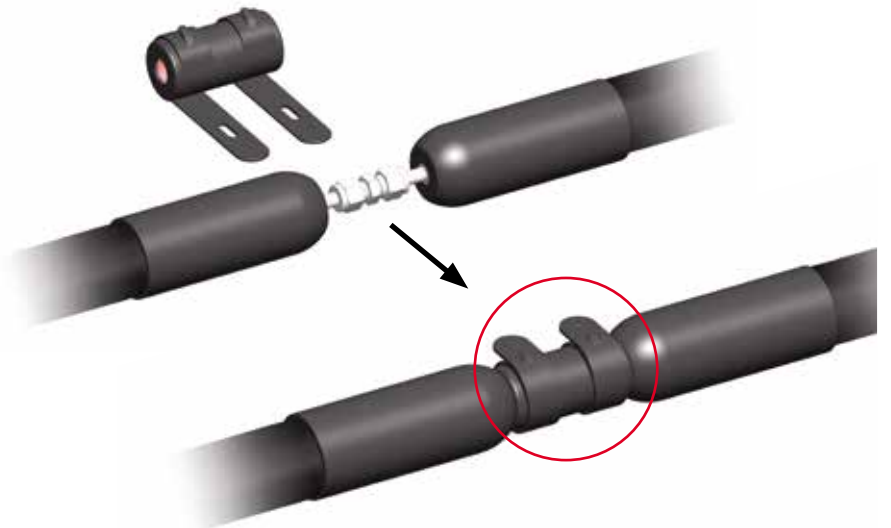

Material / features

- silicone (silicone elastomer with additives)
- outstanding mechanical and chemical resistance
- very good thermal and electrical insulation
- long term temperature stability -60°C to 200°C

Applications

- junction insulation for ferrule fittings / cutting ring screw connections to pipe OD6 mm, OD8 mm und 1/4" (OD6,35 mm)
- suitable for straight connectors
- avoids condensation in the connection area
- protection against contact and mechanical strain

Dimensions / sketch

- outer diameter: 35 mm
- inner diameter: 16 mm
- length: 70 mm

Art.-no. WAZX1132

Insulation jacket

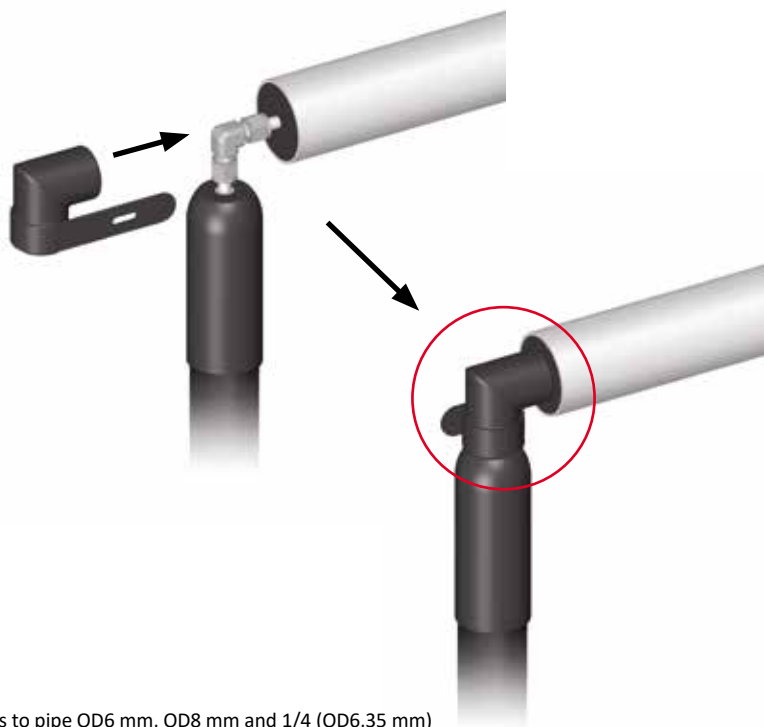

Material / features

- Silicone (silicone elastomer with additives)
- Outstanding mechanical and chemical resistance
- Very good thermal and electrical insulation
- Long term temperature stability -60°C to 200°C

Applications

- Junction insulation for ferrule fittings / cutting ring screw connections to pipe OD6 mm, OD8 mm and 1/4" (OD6,35 mm)
- Suitable for 90°-angles
- Avoids condensation in the connection area
- Protection against contact and mechanical strain

Dimensions / sketch

- Outer diameter: 35 mm
- Inner diameter: 16 mm
- Length: 60 mm

Art.-no. WAZX1027

Insulation jackets made of silicone foam

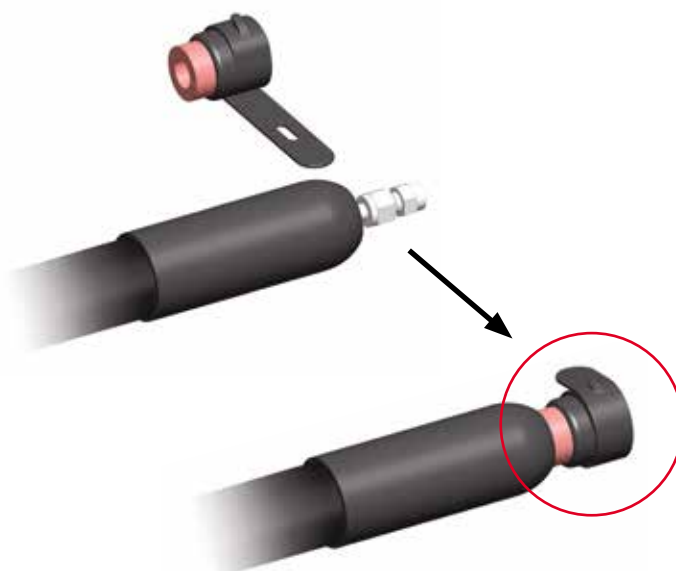

Material / features

- Silicone (silicone elastomer with additives)
- Outstanding mechanical and chemical resistance
- Very good thermal and electrical insulation
- Long term temperature stability -60°C to 200°C

Applications

- Junction insulation for ferrule fittings / cutting ring screw connections to pipe OD6 mm, OD8 mm and 1/4" (OD6,35 mm)
- Suitable for straight connectors
- Avoids condensation in the connection area
- Protection against contact and mechanical strain

Dimensions / sketch

- Outer diameter: 35 mm
- Inner diameter: 16 mm
- Length: 41 mm

11. JUNCTION HEATING FOR FERRULE FITTING

Art.-No. WZZHEATC-230XX0017-0060

Material / features

- silicone (silicone elastomer)
- outstanding mechanical and chemical resistance
- very good thermal and electrical insulation
- long term temperature stability -60°C to 200°C

Applications

- junction insulation for ferrule fittings / cutting ring screw connections to pipe OD6 mm, OD8 mm and 1/4" (OD6,35 mm)
- suitable for straight connectors
- avoids condensation in the connection area
- protection against contact and mechanical strain

Technical data

- voltage: 230 V AC
- operating temperature: 200 °C
- protection standard: IP62

Versions

- 115 V AC (other voltage on request)
- additional, permanently mounted sensor (Pt100 or NiCr-Ni type K) for reading the temperature (not for control)

Dimensions / sketch

- outer diameter: 63 mm
- inner diameter: 17 mm
- length: 60 mm

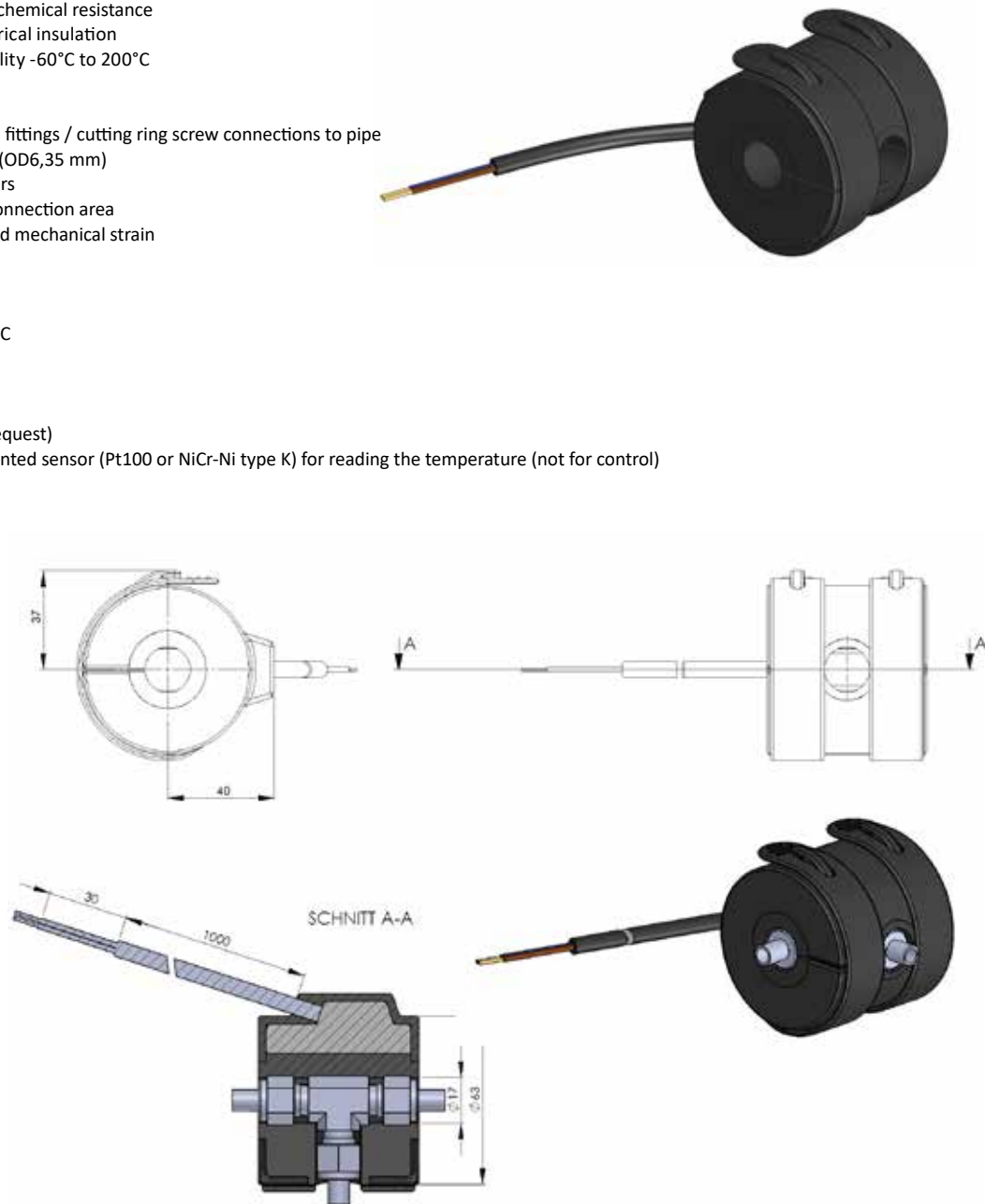

ENCLOSED ACCESSORIES

Adapter for DN 4 fittings to pipe diameter 6 mm

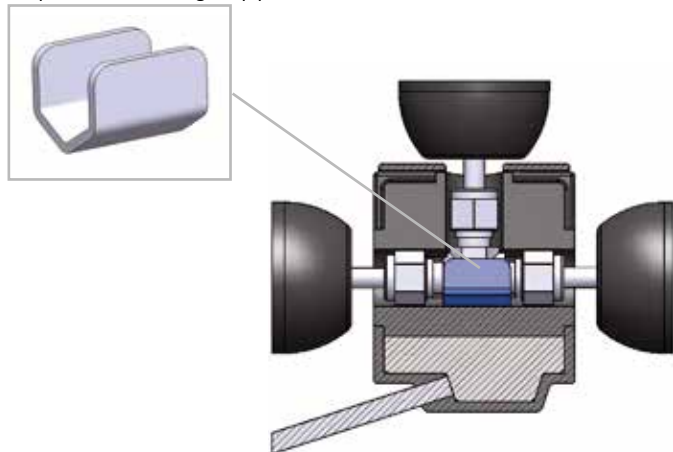

Silicone plugs for closing unused outlets

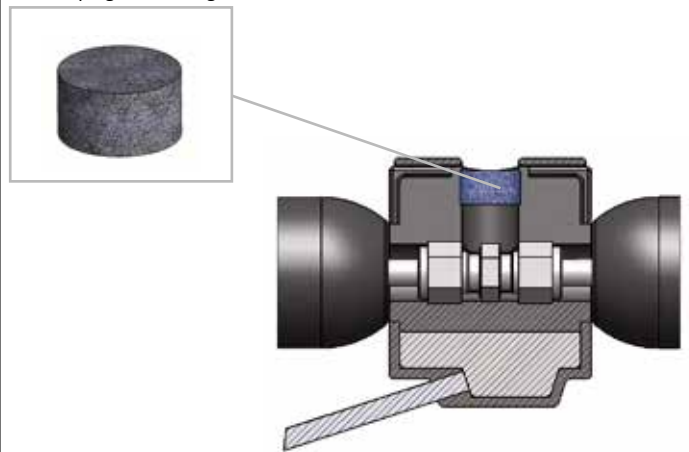

FOR YOUR NOTES

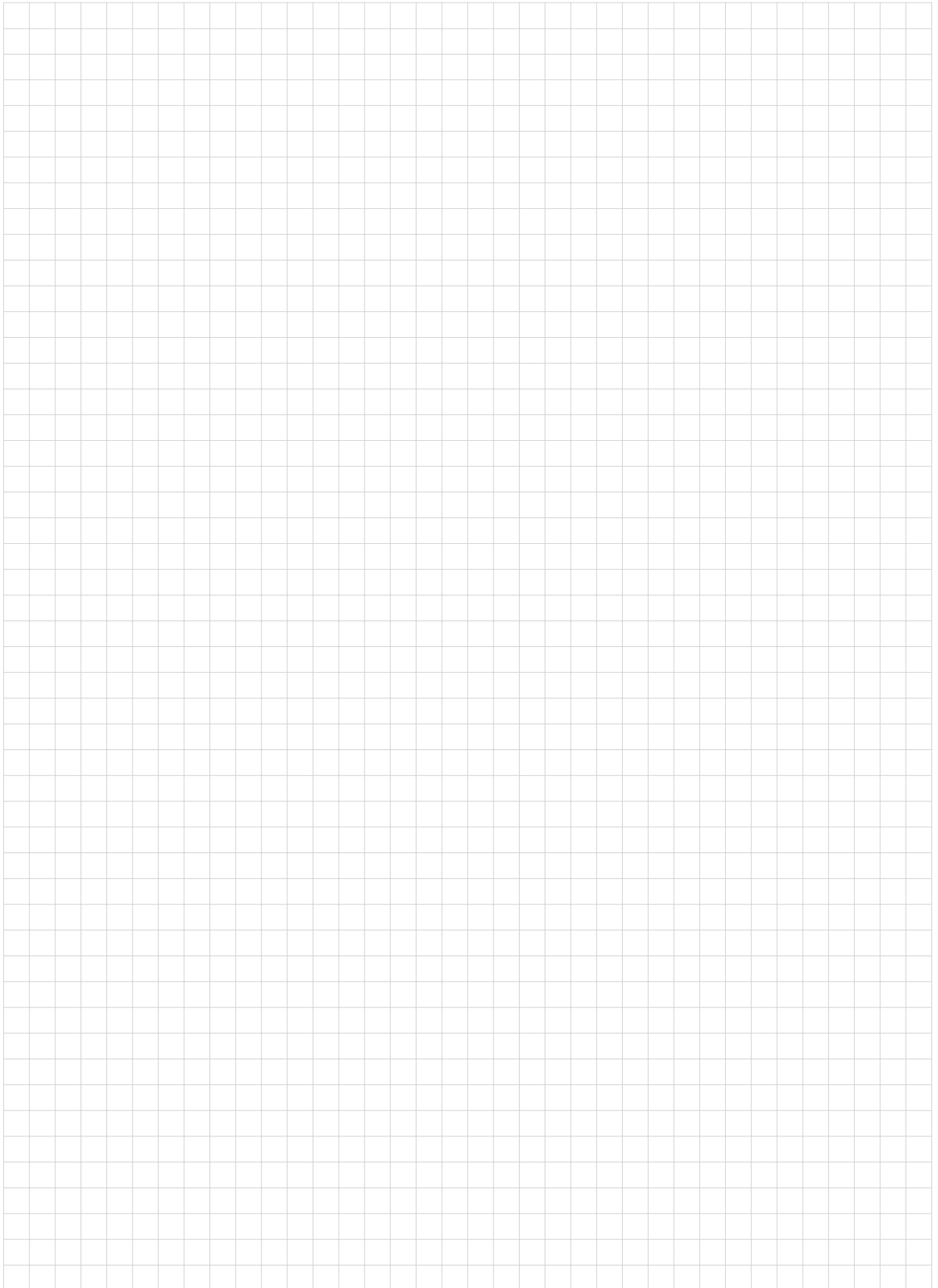

Winkler AG · Englerstrasse 24 · 69126 Heidelberg · Germany · Phone: +49 6221 3646 0 · sales@winkler.org · www.winkler.org

12. MOUNTING BRACKETS

Accessories set Art.-no. WZZFIX6B

Structure

Rubber bracket with sewn Velcro tape incl. 2 resealable cable straps in a loose insert.

Applications

Gentle mounting of heated lines and heated hoses with an outer diameter of 30 to 60 mm in horizontal and vertical position.

Benefits

- prevents kinks in the line if the bending radius is too short
- prevents constrictions in the line if mounting elements e.g. cable straps are too thin
- to screw onto aluminium profiles (fastening material not included in the scope of delivery)

Bracket material

- elastomer (EPDM rubber), black. Permanently elastic and unbreakable
- excellent resistance to chemicals and environmental pollution
- long-term heat resistance from -60 °C to + 120 °C



Dimensions:

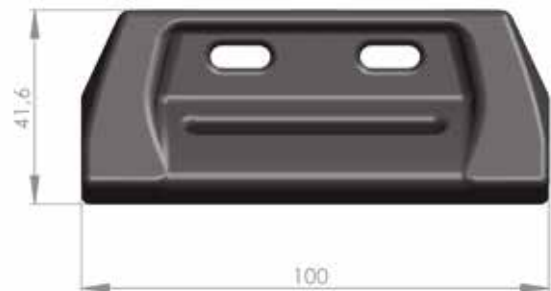
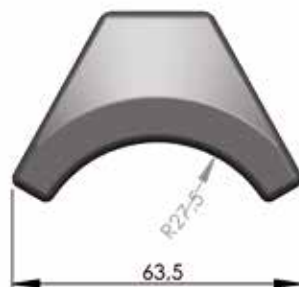

Accessories set Art.-no. WZZFIX6A

Structure

Rubber bracket with sewn Velcro tape incl. 2 resealable cable straps in a loose insert.

Applications

Gentle mounting of heated lines and heated hoses with an outer diameter of 30 to 60 mm in horizontal and vertical position.

Benefits

- prevents kinks in the line if the bending radius is too short
- prevents constrictions in the line if mounting elements e.g. cable straps are too thin

Bracket material

- Elastomer (EPDM rubber), black. Permanently elastic and unbreakable
- excellent resistance to chemicals and environmental pollution
- long-term heat resistance from -60 °C to + 120 °C



Dimensions:

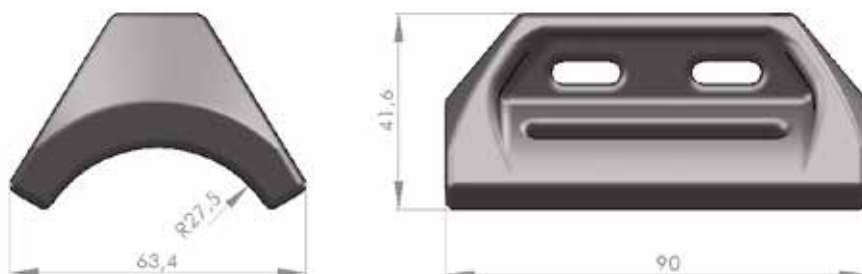

Accessories set Art.-no. WZZFIX6G

Structure

Rubber bracket with sewn Velcro tape incl. carabiner suspension device made of stainless steel.

Applications

Gentle mounting of heated lines and heated hoses with an outer diameter of 30 to 60 mm in horizontal and vertical position.

Benefits

- prevents kinks in the line if the bending radius is too short
- enables flexible suspension

Bracket material

- elastomer (EPDM rubber), black. Permanently elastic and unbreakable
- excellent resistance to chemicals and environmental pollution
- long-term heat resistance from -60 °C to + 120 °C



Dimensions:

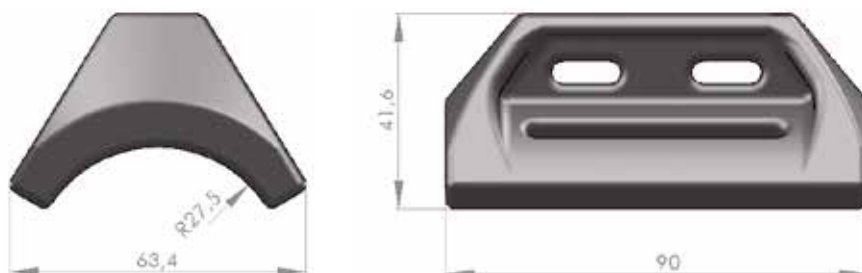

13. CONNECTION SYSTEM QUICK-LOCK

$T_{max} = 200\text{ °C}$

Application

For quick assembly of heated lines.
Used at mobile measurements.

Features and benefits

Rugged structure made of high-quality materials. The system is designed for sustained operating temperatures of up to 200°C.
Seamless (conforming to standards) heating without cold spots between the wall bushing and the heated line and the heated line coupling.

Quick-Lock for heated wall bushings

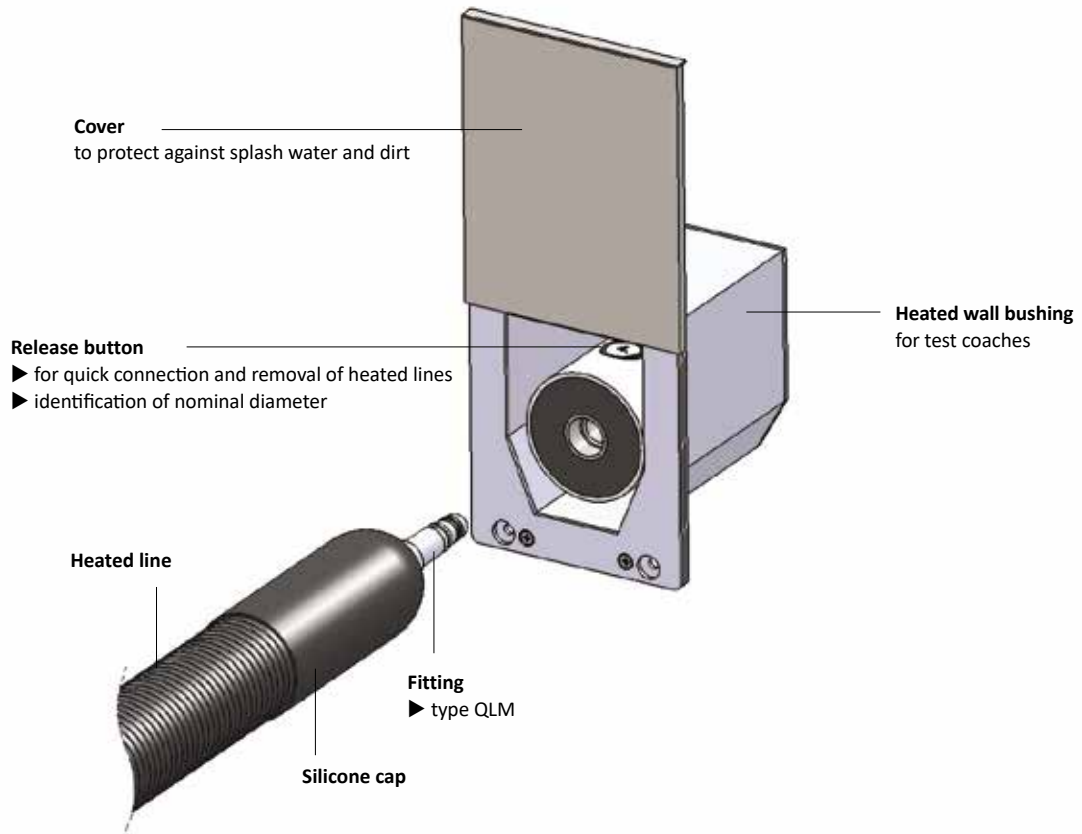

Quick-Lock for heated lines

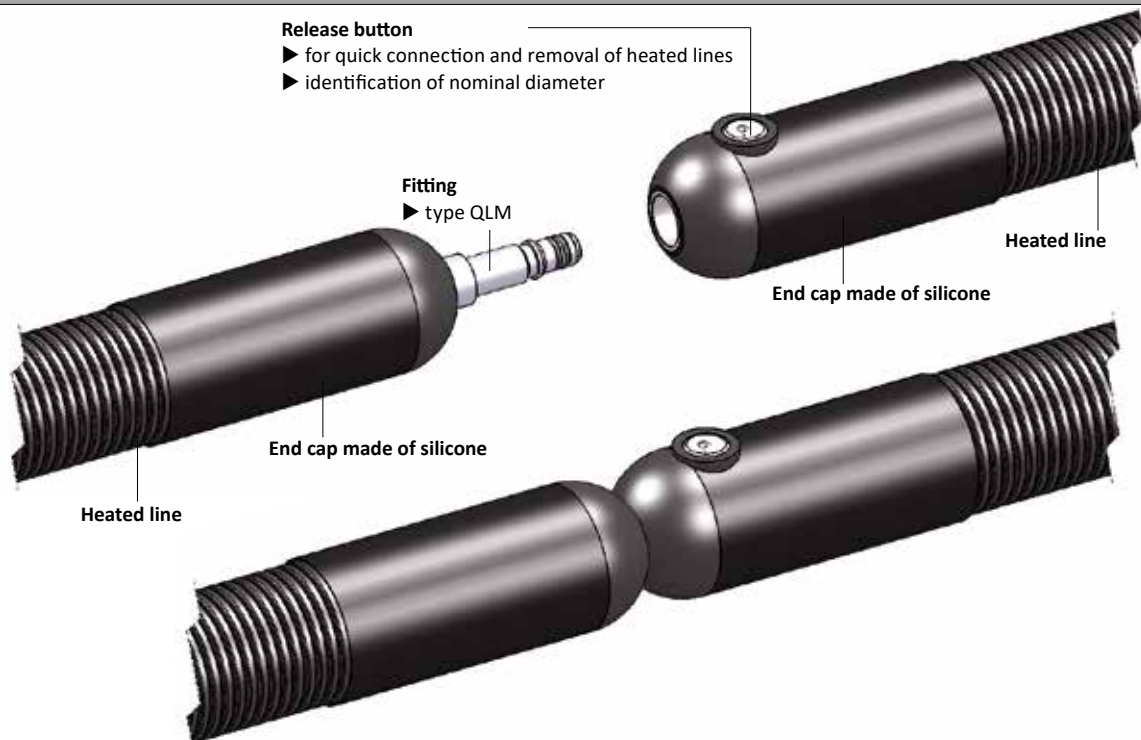

Accessories for Quick-Lock system

Winkler Quick-Lock = Connecting flexibility + gas tightness + continuous heating without cold ports!

Universal connection QLM - QLM
to connect 2 heated lines (com-
patible with DN 4 and DN 6)
Art.-no. WAZQLMMB

Fitting quick-Lock armature female (Type QLW)
available for heated lines in DN 4 and DN 6



Fitting quick-lock female (type QLW)
available for heated lines in DN 4 and DN 6

Winkler AG · Englerstrasse 24 · 69126 Heidelberg · Germany · Phone: +49 6221 3646 0 · sales@winkler.org · www.winkler.org

 <p>Universal blind plug male compatible with DN 4 and DN 6, material stainless steel</p> <p>Art.-no. WAZQLMBB</p>	 <p>Universal blind plug male compatible with DN 4 and DN 6, with safety rope for fixing, material stainless steel</p> <p>Art.-no. WAZQLMBZ</p>	 <p>Universal blind plug female compatible with DN 4 and DN 6, with safety rope for fixing, material stainless steel</p> <p>Art.-no. WAZQLWBB-BEF</p>	 <p>QL adapter female light on ferrule fitting to tube with safety rope, OD 8 mm, material stainless steel</p> <p>Art.-no. WAZQLWLK-000VZ008</p>
 <p>QL adapter male with outside thread, tapered NPT 1/8"- 27, material stainless steel</p> <p>Art.-no. WAZQLM18-NPTVZ006</p>	 <p>QL adapter male with outside thread tapered NPT 1/4"- 18, material stainless steel</p> <p>Art.-no. WAZQLM14-NPTVZ008</p>	 <p>QL bulkhead union female on tube with OD 6 or 8 mm</p> <p>Art.-no. WAZQLWGH-000VZ006 (DN 6) Art.-no. WAZQLWGH-000VZ008 (DN 8)</p>	 <p>Spare seals (O-Ring) for quick-connect master fitting 7,5 x 1,5 mm, material Viton</p> <p>Art.-no. WAZQVDRB</p>
 <p>QL fitting male for heated lines with interchangeable inner line type RW, material stainless steel</p> <p>Art.-no. BUZQW4Z4 (DN 4) Art.-no. BUZQW6Z6 (DN 6)</p>	 <p>QL adapter female on ferrule fitting to tube, OD 8 mm, material stainless steel, with silicone insulation</p> <p>Art.-no. WAZX1037-000VZ006 Art.-no. WAZX1037-000VZ008</p>	 <p>QL adapter male with RSL fitting to tube, OD 6 or 8 mm, material stainless steel, with silicone insulation</p> <p>Art.-no. WAZQLWRL-025VZ006 (DN 6) Art.-no. WAZQLWRL-025VZ008 (DN 8)</p>	

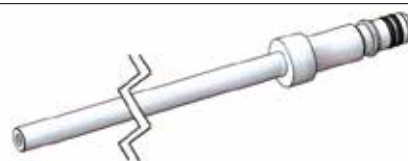

<p>Connection QLM - RSL fitting 25 mm Art.-no. WAZQLMRL-025VZ006 with OD 6 mm Art.-no. WAZQLMRL-025VZ008 with OD 8 mm</p>	<p>Connection QLM - RSL fitting 50 mm Art.-no. WAZQLMRL-050VZ006 with OD 6 mm Art.-no. WAZQLMRL-050VZ008 with OD 8 mm</p>	<p>Connection QLM - RSL fitting 100 mm Art.-no. WAZQLMRL-100VZ006 with OD 6 mm Art.-no. WAZQLMRL-100VZ008 with OD 8 mm</p>
<p>Connection QLM - RSL fitting 150 mm Art.-no. WAZQLMRL-150VZ006 with OD 6 mm Art.-no. WAZQLMRL-150VZ008 with OD 8 mm</p>	<p>Connection QLM - RSL fitting 200 mm Art.-no. WAZQLMRL-200VZ006 with OD 6 mm Art.-no. WAZQLMRL-200VZ008 with OD 8 mm</p>	<p>Connection QLM - RSL fitting 500 mm (soft annealed) Art.-no. WAZQLMRL-500VZ006 with OD 6 mm Art. no. WAZQLMRL-500VZ008 with OD 8 mm</p>

14. HEATED FILTER SERIES WAZF

$T_{max} = 200\text{ °C}$

Application

The heated filter element filters e. g. soot particles from measurement gases. Contamination of the analyser is thus prevented.



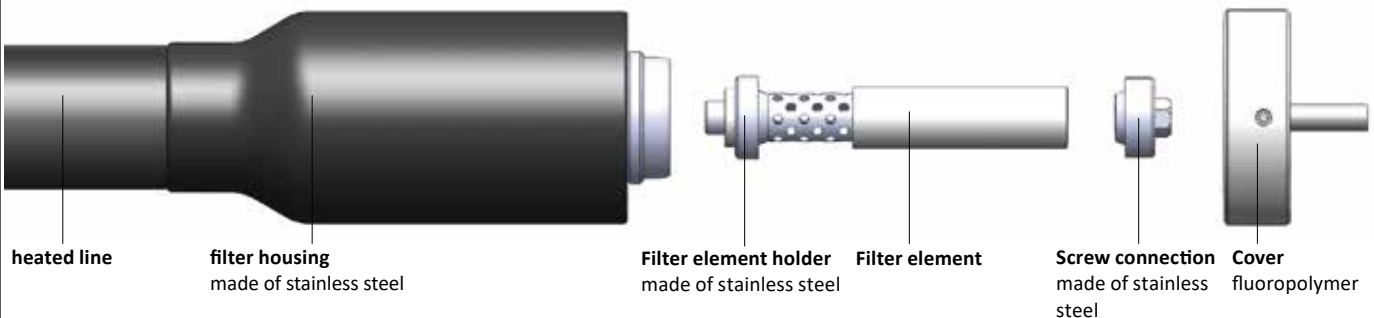

Structure



Versions heated filter cartridges, filter element holders and filter elements

<p>Filter cartridge Art.-no.: WAZF0250</p> <p>Technical Data:</p> <ul style="list-style-type: none"> · filter fineness: 2 µm, up to 200°C · filter surface: 300 cm² · material: Stainless steel 1.4571 · supporting pipe made of stainless steel 1.4301 · multipath use; may be cleaned in an ultrasonic bath 	
<p>Filter element holder with screw connection Art.-no.: WAZF0270</p> <p>Technical Data:</p> <ul style="list-style-type: none"> · material: Stainless steel 1.4571 / 1.4404 · for filter elements with ID min = 16 mm / OD max = 24 mm / L = 65 mm 	
<p>Filter element Art.-no.: WAZF0261-016TS065</p> <p>Technical Data:</p> <ul style="list-style-type: none"> · filter fineness: 2 µm, up to 200°C, used with filter element holder WAZF0270 · filter surface: 88 mm² · material: Sintered PTFE · one-way use · ID = 16 mm / OD = 20 mm / L = 65 mm <p>Other filter fineness on request.</p>	<p>Filter element on filter element holder</p>
<p>Filter element Art.-no.: WAZF0261-016MG065</p> <p>Technical Data:</p> <ul style="list-style-type: none"> · Filter fineness: 2 µm, up to 200°C, used with filter element holder WAZF0270 · filter surface: 88 mm² · material: Micro-glass fiber · one-way use · ID = 16 mm / OD = 20 mm / L = 65 mm <p>Other filter fineness on request.</p>	<p>Filter element on filter element holder</p>

<p>Filter element Art.-no.: WAZF0261-016VZ065</p> <p>Technical data:</p> <ul style="list-style-type: none"> · filter fineness: 2 µm, up to 200°C, used with filter element holder WAZF0270 · filter surface: 39 cm² · 5-layer sintered stainless steel mesh, 1.4401 · multipath use; may be cleaned in an ultrasonic bath · ID = 16,6 mm / OD = 20 mm / L = 62 mm 	 <p style="text-align: center;">Filter element on filter element holder</p>
<p>Filter holder for ceramic composite filter Art.-no.: WAZF0272</p> <p>Technical data:</p> <ul style="list-style-type: none"> · material: Stainless steel 1.4571 / 1.4404 · for filter elements with · ID min = 19 mm / OD max = 30 mm / L = 75 mm 	
<p>Filter element Art. Nr.: WAZF0273-020KX075</p> <p>Technical data:</p> <ul style="list-style-type: none"> · filter fineness: 1,5 µm, up to 200°C · filter surface: 70,7 cm² · material: ceramic / white · one-way use · ID = 20 mm / OD = 30 mm / L = 75 mm <p>Other ceramic composite materials on request.</p>	

Accessories and spare parts for heated filter elements			
			
<p>Flat gasket Art.-no.: WAZF0261-000V1000</p> <p>Technical data:</p> <ul style="list-style-type: none"> · material: Viton 	<p>Filter holder seals for ceramic composite filter Art.-no.: WAZF0272-030V1000</p> <p>Technical data:</p> <ul style="list-style-type: none"> · material: Viton 	<p>Special mounting tool Art.-no.: WAZF0251</p> <p>Technical data:</p> <ul style="list-style-type: none"> · material: red anodized aluminium · SW10 for filter element type WAZF0250 and WAZF0270 	<p>Thread grease Art.-no.: WAZF0253</p> <p>Technical data:</p> <ul style="list-style-type: none"> · content: 9 g
		<p>also available as a set: Accessory set for filter housing Art. No.: WZZX1003, consisting of special mounting tool WAZF0251 and thread grease WAZF0253</p>	

Heated filter housing with soot particle filter
 Art.-no.: WAFRUSSP-230XP006-00004P15

Application:
 To filter sooty and oily exhaust gases.

Filter housing structure:



filter housing

filter wad
glass fibre

filter holder
stainless steel

screw cap
insulation PTFE

seive
stainless steel

filter wad
glas fibre

Advantages:

- simple opening and closing the filter housing
- easy changing of the filter wad

Accessories:

- Art.-no. **WAZFRUWA** filter wad, glass fibre
- one packaging unit in PE bag, **not** included in delivery

Technical data	
max. permissible operating temperature	200 °C
operating voltage	230 V*
power	max. 45 W
sensor	Pt 100 (2-wire technology)
length	130 mm
outer diameter	62 mm
weight	ca. 800 g
fittings	Pipe socket, stainless steel* DN6 (ID 6 / OD 8 mm), LA 25mm Pipe socket, stainless steel* DN4 (ID 4 / OD 6 mm), LA 25mm

*others on request

LA: length of fitting
 OD: outer diameter fitting
 ID: inner diameter fitting

Accessory set WZZFRUTO

Included with initial delivery

content:

Special tool and thread grease

- tool **WAZFRUTO** for soot particle filters for inserting the filter wad and to easily remove the soiled filter wad after use
- thread grease **WAZF0253** for greasing the thread on the filter housing

SOOT PARTICLE FILTER - FILLING

Accessories: Tool for Plugging / Removing a filter wad
Art.-no.: WAZFRUTO

1. Plugging fresh filter wad

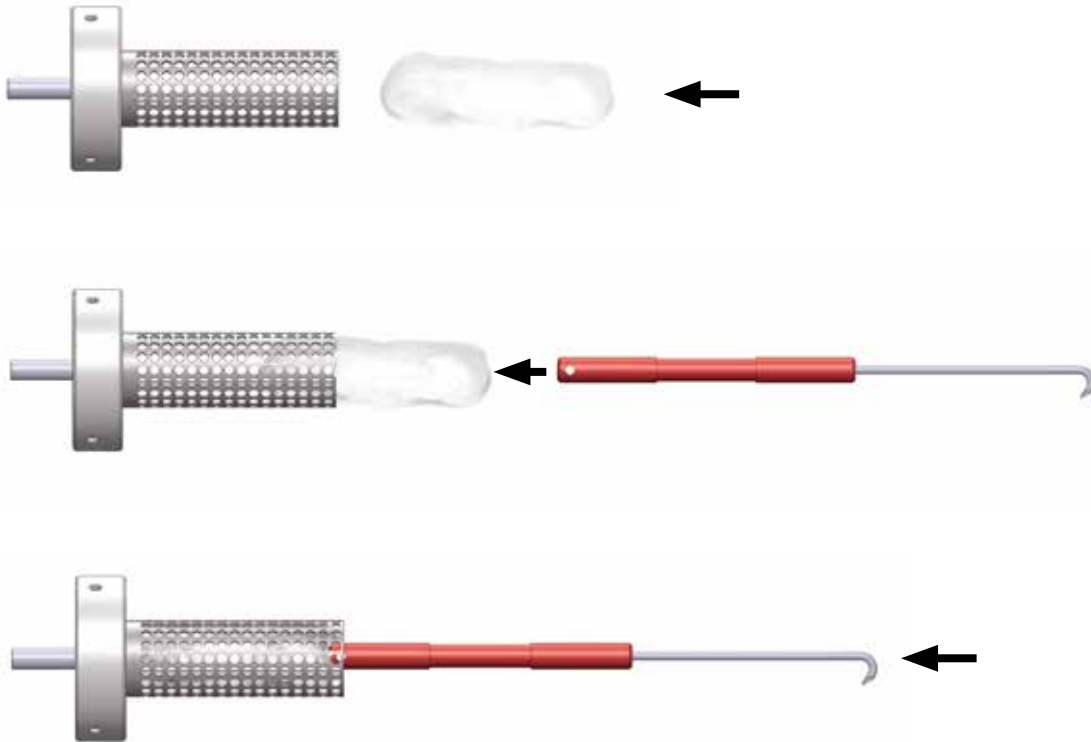

2. Removing soiled filter wad

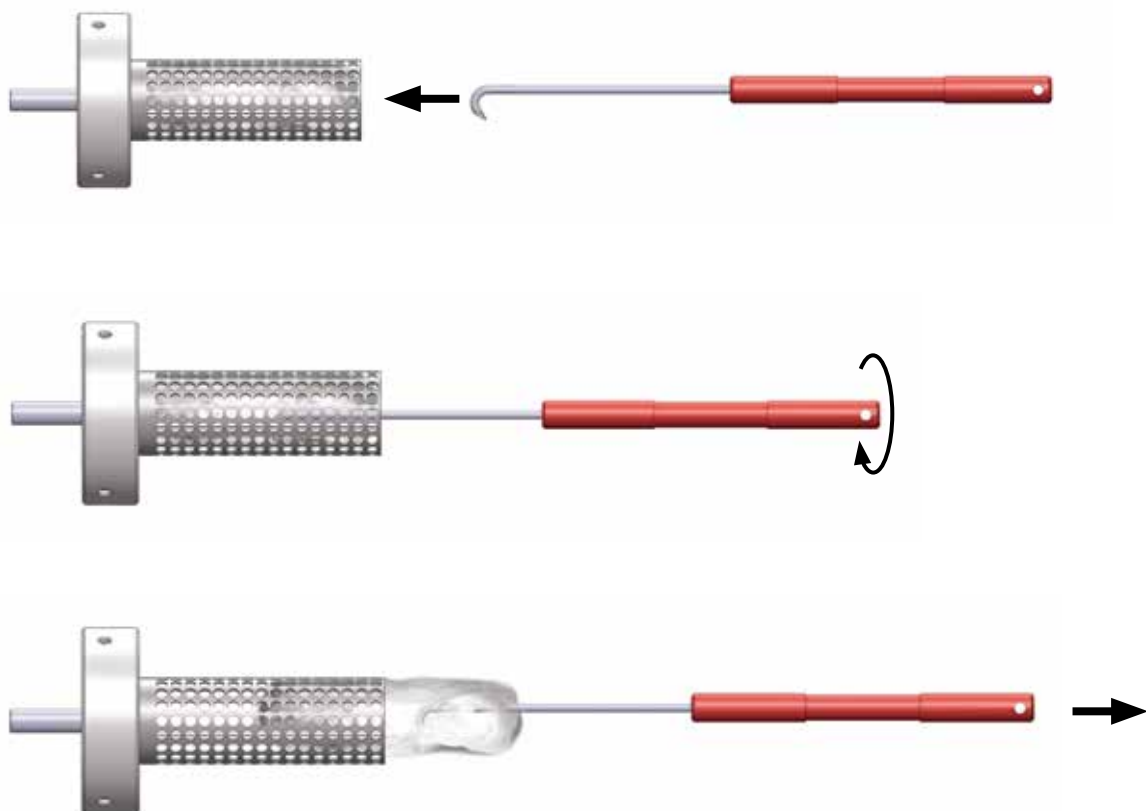

1.15 HEATED MIXING VESSEL

$T_{max} = 200\text{ °C}$

Application

For environmental and process measurement; for mixing, buffering and putting gases through. The heated mixing vessel is used for connecting several heated lines with pumps and headrace.

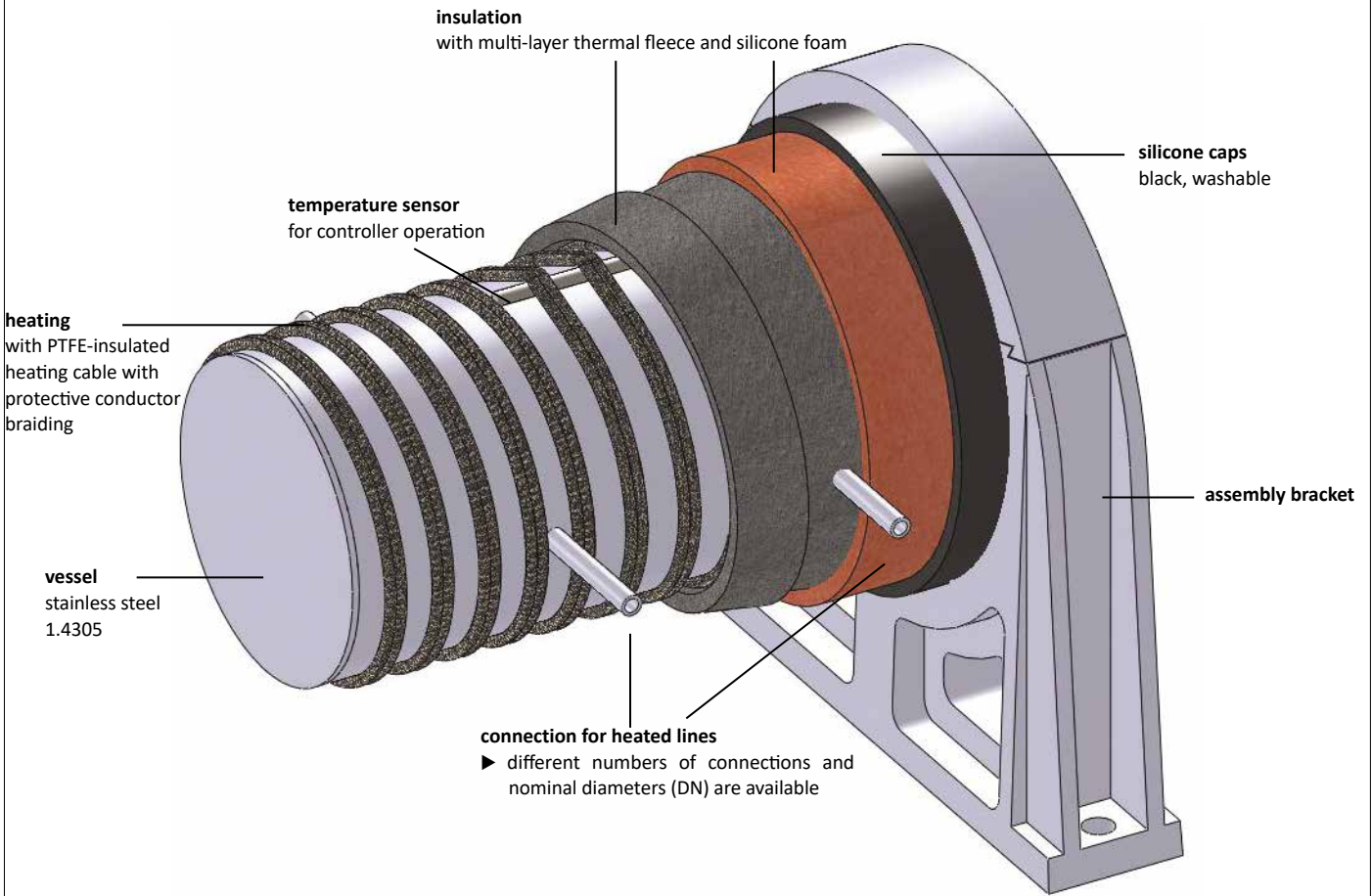

Features and benefits

- very robust structure made of high-quality material. Made for continuous use and temperature range up to 250 °C
- the cylindrical shape guarantees a very good mixing of the gases
- efficient heating due to the very good insulation
- ▶ low input: only 150W (200 °C)
- connections for heated lines can also be used as additional cold junction for cooling gases down
- delivery with insulation jacket (accessories)
- buffer volume 1,1 l - others upon request



Versions of silicone caps



Code SB
Silicone cap, black, washable.
Very robust; protects the insulation.



Code SR
Silicone cap, red, washable.
Very robust; protects the insulation.



Code SY
Silicone cap, yellow, washable.
Very robust; protects the insulation.

Sensors

- XM** Temperature sensor Pt 1000 (2 Leiter)
- XP** Temperature sensor Pt 100 (2 Leiter)
- XK** Thermo couple type K (NiCr-Ni)
- XJ** Thermo couple type J (Fe-CuNi)

Optionen für Anschlüsse

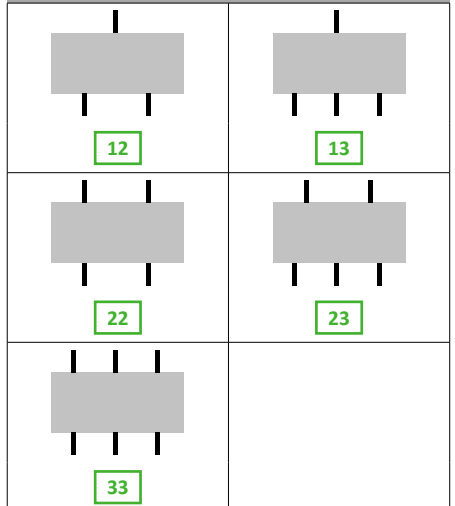

Up to three connections on each side are possible.

Technical data

Model	2 x 2-ways connection
D: diameter	130 mm
L: length	200 mm or acc. to customer specification
A: length connection	20 mm
DN: nominal diameter	DN 6; ID 6mm others on request
assembly bracket	
HM: height	188 mm
LM: length	40 mm
BM: width	183 mm

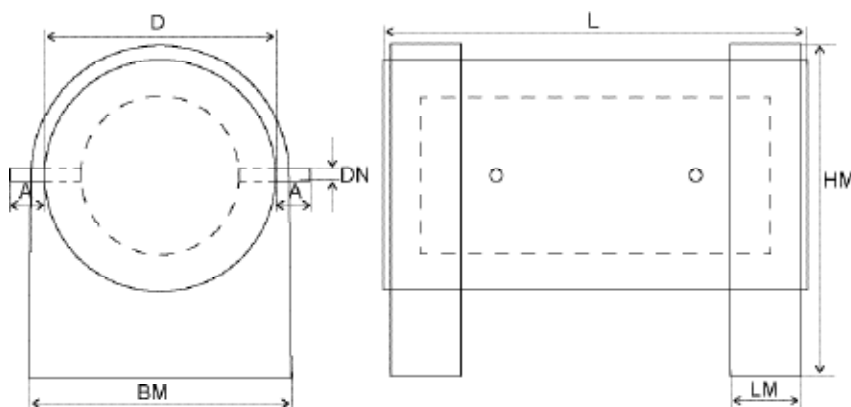

Connection

The connection of the heated lines with the heated mixing vessels occurs with ferrule fittings.

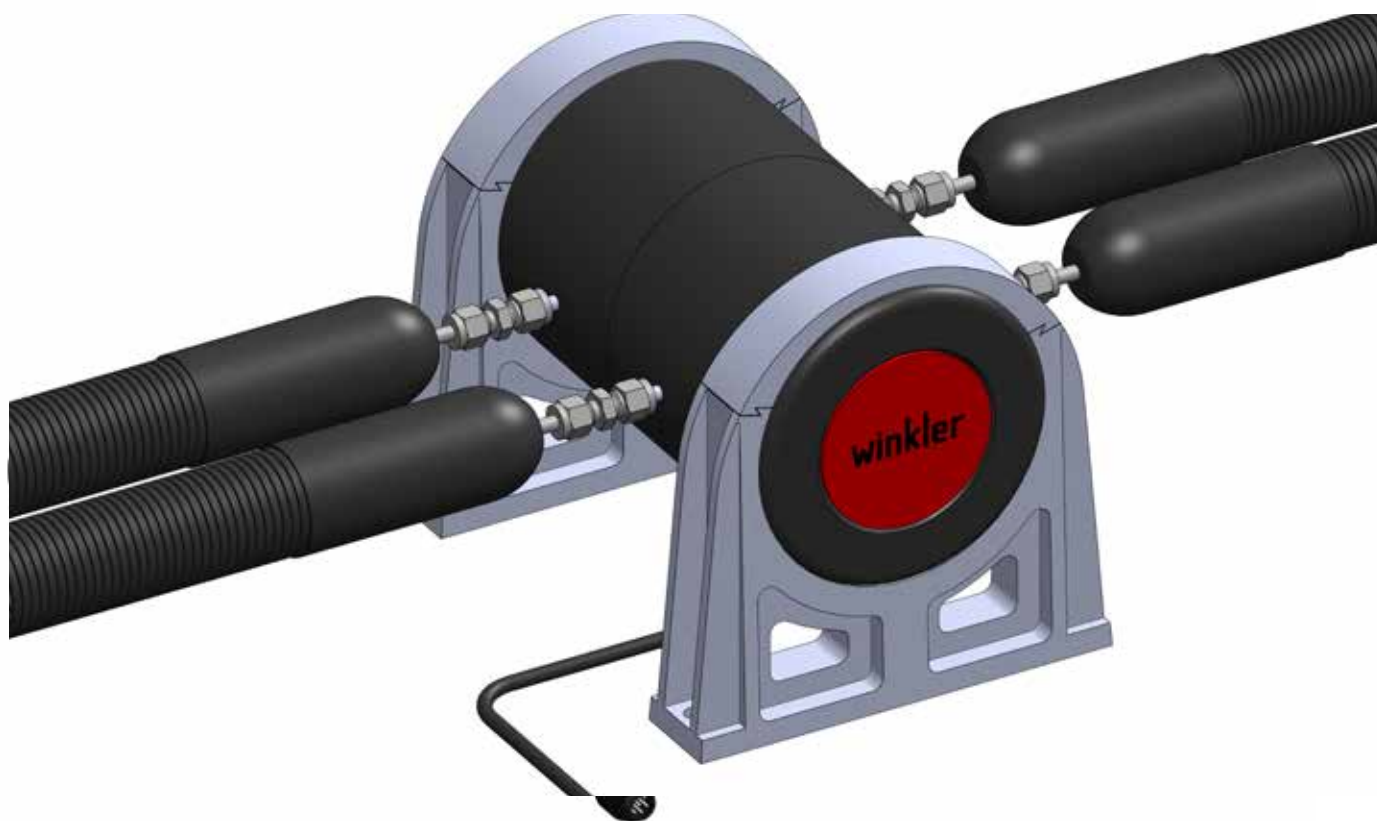

Accessories



Insulation jacket
silicon foam hose with black silicon cover,
fixing with Velcro

Art.-no.: **WAZX1020**



Double ferrule fitting dn6
Art.-no.: **WAZISWAG**

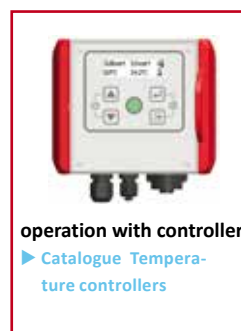

operation with controller
▶ [Catalogue Temperature controllers](#)

Applications

Heating of sampling and conditioning components for hot-wet measurements.

The product series was developed with a special view to simple integration in analysis systems and its modular structure and pre-punched openings make it easier for the user to establish fast connections to heated lines, pumps and analysers. Highly efficient insulation and a thermally decoupled internal structure allow continuous operation up to 200 °C with a very low power requirement.

Structure

- Housing made of powder-enamelled steel plate in a modular design with pre-punched openings all round for easily creating ports, e.g. for electrical connections or for connecting heated lines.
- Highly efficient thermal insulation with pre-punched insulation plugs at the connection points. This avoids heat losses and cold spots at the junctions.
- Uniform heating with surface heating elements that may either be arranged on the sides or at the bottom.
- integrated temperature sensors for external regulation (standard Pt100, thermocouples also available)
- Fully thermally decoupled mounting frame with base plate made of stainless-steel perforated plate for fast and flexible configuration of the components to be heated.
- separately mountable front plate (OEM designs possible on request)

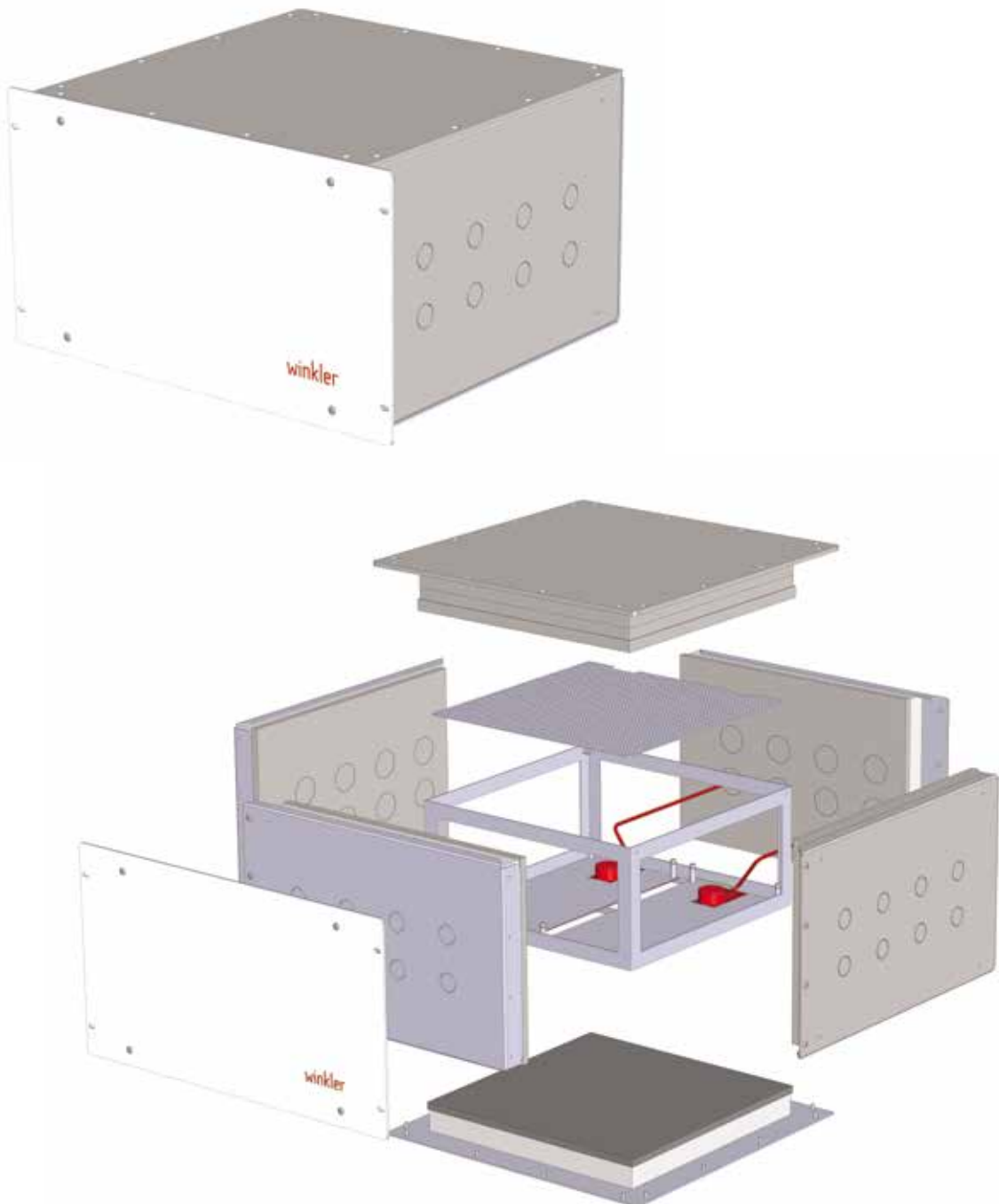

Installation

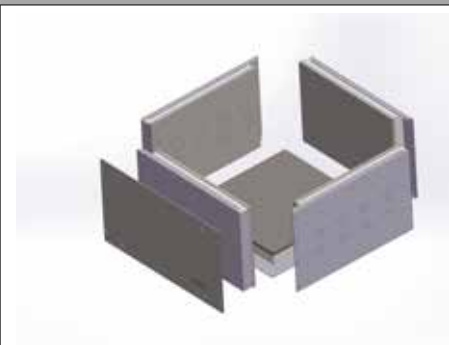

arrangement of the components on the base plate

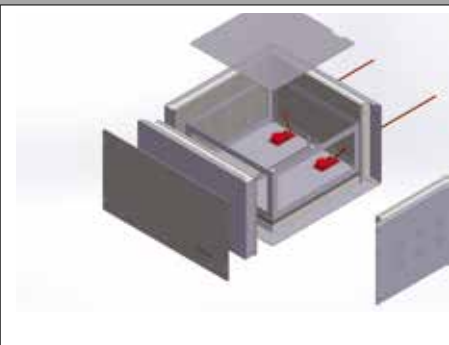

insertion of the base plate
insertion of the heating elements



establishing the port openings

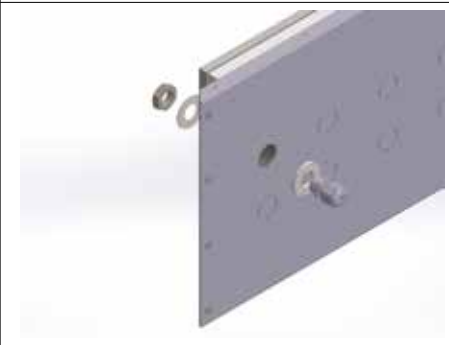

installation of the ports and internal cladding

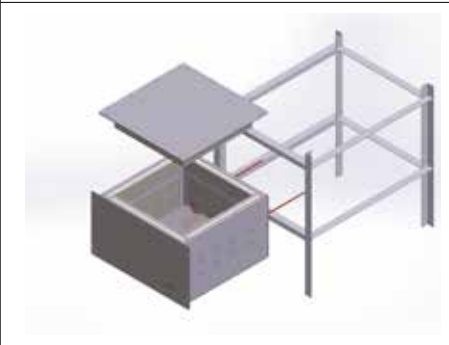

closing the cover and mounting the housing in the rack

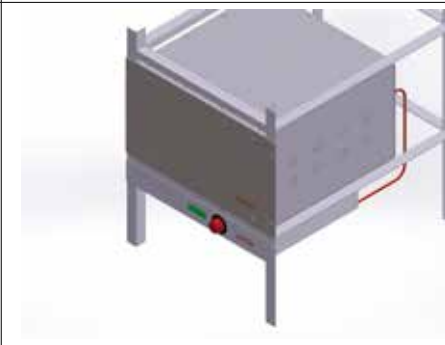

connecting the lines

Technical data

article number	WAV19486-230XP102
external dimensions (WxdxH)	420 x 420 x 268 mm (6 HE)
internal dimensions (WxdxH)	336 x 336 x 135 mm (15 litre utilisable volume)
dimensions of base plate	320 x 320 mm (drill holes 4 mm)
heating	2 x heating elements each 100 W (230 V AC) with integrated limiter (220°C)
temperature sensor	1 x Pt 100

Other dimensions and OEM design possible on request.

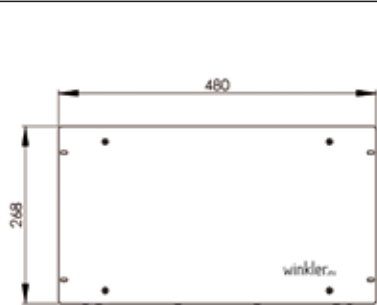

front plate

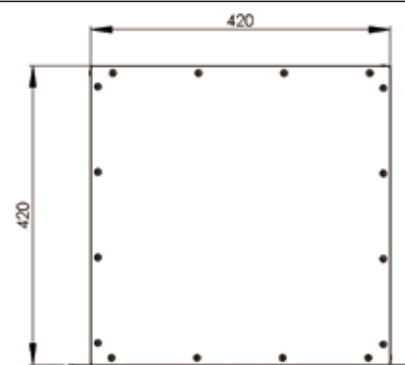

plan view

Accessories



bulkhead connector



quick-lock bulkhead union female on tube
with OD 6 or 8 mm
Art.-Nr. **WAZQLWGH-000VZ006** (DN 6)
Art.-Nr. **WAZQLWGH-000VZ008** (DN 8)

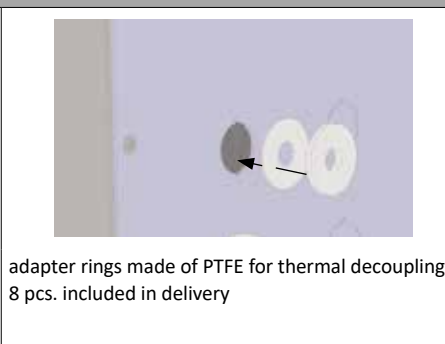

adapter rings made of PTFE for thermal decoupling
8 pcs. included in delivery



controller with 19" housing (image similar)



wall bracket for 19" housing

A large grid area for taking notes, consisting of 20 columns and 40 rows of small squares.

FOR YOUR NOTES

Winkler AG · Englerstrasse 24 · 69126 Heidelberg · Germany · Phone: +49 6221 3646 0 · sales@winkler.org · www.winkler.org

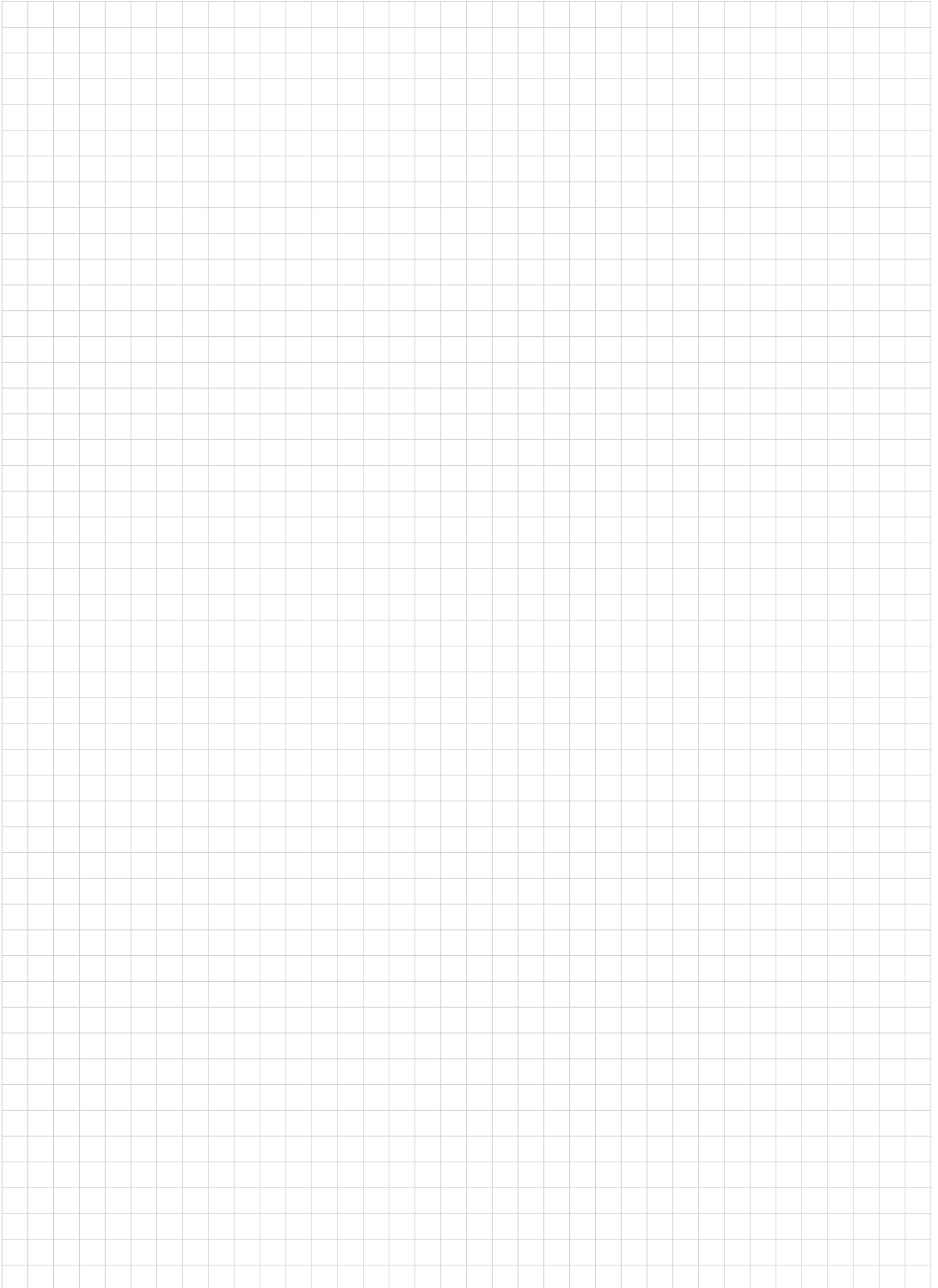

**ANY QUESTIONS?
PLEASE FEEL FREE
TO CONTACT US!**



Your contact:
Rolf Grotenrath
Head of Sales

Mobile: +49 162 2906013

winkler

Winkler AG
Englerstrasse 24
69126 Heidelberg
Germany
Phone +49 6221 3646 0
sales@winkler.org
www.winkler.org